

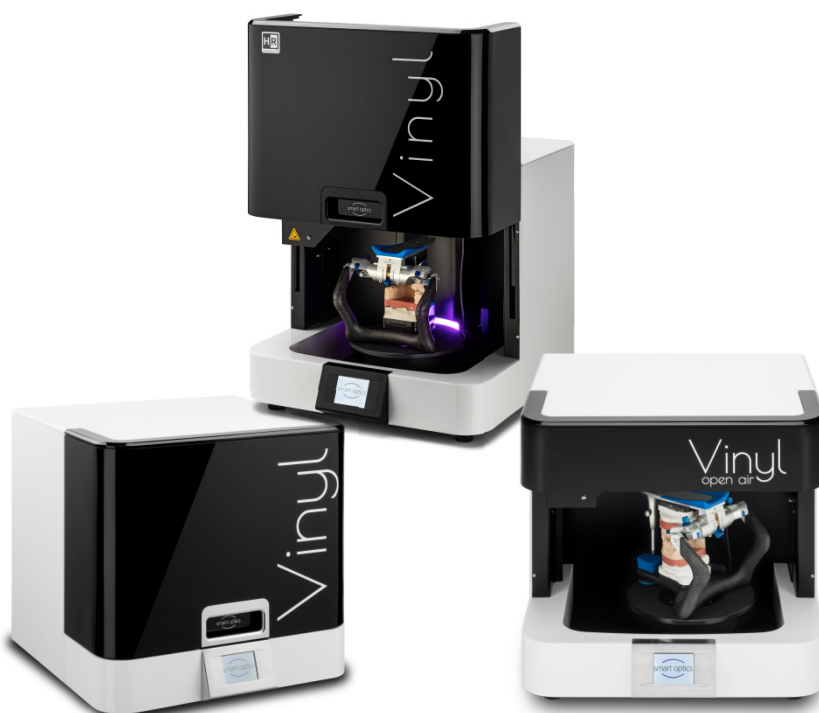

Operating Manual

Prosthetic Scanners



reddot award 2018
winner

Vinyl Series

A product from smart optics Sensortechnik GmbH



Legal Notice

Dear customer,

Thank you for choosing a product from smart optics!

If you require additional information or if you have any questions about the device, please contact your smart optics reseller. Our trained resellers around the world provide first-level support as well as training and service for all applications.

We wish you much joy with your scanner!

Your smart optics team

PRIZES AND AWARDS

In 2018, Vinyl received the Red Dot Design Award in the category "Industrial Equipment, Machinery and Automation": www.red-dot.org/de/project/vinyl-24269

CHANGES AND SERVICE

We reserve the right to implement product changes as part of continuous improvement and technical progress and to make changes to this documentation. You can find the current version of this documentation on our homepage: www.smartoptics.de.

Please note that the current version of this documentation may contain information which does not apply to older devices.

On request we are also glad to send you a printed paper version of the documentation. Please send us an e-mail to communications@smartoptics.de.

If you are looking for a reseller in your area, please use the contact form for Sales on our homepage www.smartoptics.de.

BRANDS AND TRADEMARKS

Windows, .NET Framework and Visual C++ are registered trademarks of Microsoft Corporation.

FlyCapture and UpdatorGUI are registered trademarks of Point Grey Research, Inc.

exocad is a registered trademark of exocad GmbH, D-64293 Darmstadt.

Adesso Split and Artist/arTO are registered trademarks of K. Baumann, D-75210 Keltern.

SAM is a registered trademark of SAM Präzisionstechnik GmbH, D-82131 Gauting.

Artex is a registered trademark of Amann Girrbach AG, A-6842 Koblach.

Gamma is a registered trademark of Gamma medizinisch-wissenschaftliche Fortbildungs-GmbH, A-3400-Klosterneuburg.

PROTAR is a registered trademark of KaVo Dental GmbH, D-88400 Biberach/Riß.

Denar is a registered trademark of Whip Mix Corporation, Louisville, KY 40209, USA.

Triple Tray is a registered trademark of Premier Dental, Plymouth Meeting, PA 19462 U.S.A.

Where products belonging to other owners are referenced, we wish to point out that these are brands of the relevant owners that are protected by copyright laws.

Royalty-free icons and illustrations from the Flaticon.com, Fotolia.com, Freepik.com and Pixabay.com image agencies were used in this operating manual.



Table of Contents

1.	About this manual.....	5
2.	For your safety	11
2.1.	Proper use	11
2.2.	General safety instructions	12
2.3.	Symbols on the device.....	22
3.	Scope of delivery	24
4.	Device components	29
4.1.	Front view.....	29
4.2.	Internal view	31
4.3.	Views of the accessories (standard scope of delivery).....	33
4.4.	Connections and type plate (rear view)	35
5.	Setup and commissioning of the scanner	36
5.1.	Choosing a workstation	36
5.2.	Unpacking the scanner.....	36
5.3.	Connecting the scanner	41
5.4.	Opening and closing the scanner.....	43
6.	The object holder system	44
6.1.	Overview	44
6.2.	Matting the surface with 3D scan spray	45
7.	Positioning of a single jaw model	46
7.1.	Inserting a jaw model with a Multisplit mounting plate	46
7.2.	Inserting a jaw model with an adapter plate.....	48
7.3.	Inserting a jaw model with an object holder.....	51
7.4.	Fastening gingiva, squeeze bites, scanbodies or wax-ups..	54
8.	Positioning of non-articulated occlusion models	55
8.1.	Fastening an occlusion model with a rubber band.....	55
8.2.	Fastening of an occlusion model with an occlusion clamp.	57



- 9. Positioning of articulated occlusal models.....59
 - 9.1. Positioning of an occlusal model with an articulator 59
- 10. Positioning tooth stump models with the multiDie adapter 62
- 11. Positioning of aTriple Tray® impression 65
- 12. Positioning objects (universal mode).....69
 - 12.1. Fastening objects on the flexible object holder 70
 - 12.2. Inserting the object holder..... 72
 - 12.3. Removing the object holder..... 73
- 13. Positioning the calibration model 74
- 14. Operating principle of the scanner 76
 - 14.1. Operation via touchscreen..... 77
 - 14.2. Switching between LR and HR mode 79
- 15. Device maintenance 79
- 16. Faults and repairs 81
- 17. Environmentally-friendly disposal 82
 - 17.1. Disposal of the packaging 82
 - 17.2. Disposal of the device 82
- 18. Technical specifications.....83
- 19. Declaration of CE conformity 86
- 20. Short guide to commissioning..... 87
- 21. Glossary.....89
- 22. Index.....91



1. About this manual

Please read through this operating manual carefully. Keep the operating manual in a safe place. If you pass on the product to somebody else, please make sure that you hand them this operating manual as well.

smart optics accepts no liability for damages due to failure to comply with the operating manual.

Introduction

The scanners of the "Vinyl" product family are 3D desktop scanners primarily used to digitize jaw models. Dental laboratories benefit from the precision, speed, durability and great functionality of these devices. Their outstanding technical features include: a fully automatic Z-axis, a 180-degree opening that allows open scanning and a touchscreen for easy operation.

Thanks to the large Vinyl system plate, articulators can be scanned; for certain makes condyle-related, otherwise average.

Vinyl Open Air

The fully open Vinyl Open Air model provides a solid basic configuration with the most important modules, and it can be expanded when necessary.

Vinyl

The Vinyl standard model is equipped with all modules and also with a lid, allowing closed scanning when necessary.

Vinyl High Resolution

The high-end model Vinyl High Resolution is the only scanner in the series with a high-resolution camera, a blue light LED and a LED status indicator.

Universal mode

All scanners of the Vinyl series can be operated in Universal Mode and can therefore be used independently of the dental technology for the high-precision scanning of objects. In the Universal Mode, solid objects that are dimensionally stable, such as tools, jewelry, or toys that are with a maximum size of 80 × 60 × 85 mm (XYZ) and a maximum weight of 0.938 kg can be scanned.

You can edit the scan data in the open PLY or STL format with most common CAD systems and print the shapes with a 3D printer.

To use the universal mode, dental Scan 3.1.0 or higher is required.



Users of the Universal Mode can limit the reading of this manual to chapters 1 – 6 and 12 – 20.

What operating manuals are available?

Generally there are several manuals for smart optics scanners:



Operating manual

This manual contains the description of the device components, the general notes on safety and the technical data. They will tell you how to operate the scanner and how to handle the accessories.



Installation manual

Here you will find out how to install the dental Scan scanner software for the first time and how to receive and install updates at a later date.



dental Scan user manual

All scanning methods and the use of optional modules are described in this manual.

Graphic symbols and highlighting of important information

In this manual, graphic symbols and text highlights are used to present the information more clearly. In this way you may understand the instructions better.

- ▶ A triangle on the left indicates a step involving an action.
- ✓ A tick on the left tells you what the outcome should be if you have followed one or more steps correctly.
- 1. An element in a sorted list
- An element in an unsorted list
- A list of recommendations or action alternatives

Important statements are highlighted in bold type.

Important **KEYWORDS** are highlighted with capital letters in bold type.

Chapter NN
 Page NN

Cross-references within a manual are highlighted with a book icon. Cross-references act as hyperlinks in the electronic version. Click on the number to follow the link. The page navigation of the PDF reader returns you to the starting point (“Previous view” or “Back”).



Cross-references to other manuals are highlighted with a symbol for the type of manual: a scanner for the operating manual, a software package for the installation manual and a user on the PC for the dental Scan user manual.



The signpost shows a selection of topics related to your current issue.



This icon points towards functions or modules that are not included in the standard scope of delivery and that can be purchased separately.



Variants in operation and functionality which do not apply to this scanner type are marked with this symbol.



Standard settings specified by the manufacturer are indicated with a steering wheel.



TIP

The word “Tip” and the information icon are used to highlight tips on operation and information that require your special attention.



The manufacturer of the product is indicated by the factory symbol.

Figures

Figures showing equipment and screenshots from the software are used for illustration purposes.

The images shown in this manual may differ from the appearance of your actual device or from the software supplied with your device. The screenshots show realistic examples but do not contain actual data.



Software controls

The software controls are highlighted as follows:

OK Names of buttons in the software are shown with a colored background.

Name Names of fields in the software are highlighted in bold type.

File | New Names of menus and menu options are separated by a vertical line.

Name .txt File and path names are shown in Courier font.

Units of measurement and numbers

In this manual the numbers are given according to the decimal system with decimal places.

Units of measurement comply with the legal units in Germany as well as the international system of units (SI).

Further information as well as measurement converters can be found on the Internet.

Measurement	Unit	Abbreviation
Mass/weight	Kilogram	kg
	Gram	g
Length	Meter	m
	Centimeter	cm
	Millimeter	mm
	Micrometer	μ
Angle	Degree	°
Time	Hour	h
	Minute	m
	Second	s
Electrical power	Watt	W
Electrical voltage	Volt	V
	Alternating current	AC



Measurement	Unit	Abbreviation
Electrical frequency	Hertz	Hz
	Gigahertz	Ghz
Electrical current	Ampere	A
Protection class	International Protection	IP 1 st digit: solids protection; 2 nd digit: fluids protection
Temperature	Degree Celsius	°
Memory (PC)	Random-Access Memory	RAM
Data volume	Megabyte	MB
	Gigabyte	GB
CAD data format	Polygon file format	PLY
	Standard Triangulation Language	STL
	American Standard Code for Information Interchange	ASCII
	Mesh	
	Point Cloud Measurement	MSH PCM
Picture element	Pixel	Px (monitor) dpi (print)
	Megapixel	Mpx



Warnings

Warnings provide information on how damage to objects and injury to persons can occur and give instructions on how to avoid risks. Warnings are categorized into four levels depending on the severity of the possible consequences.



NOTE

This combination of signal word and symbol warns you about possible *material damage* that might occur if the instructions are not followed correctly.



CAUTION

This combination of signal word and symbol warns you about possible *minor injuries* that might occur if the instructions are not followed correctly.



WARNING

This combination of signal word and symbol warns you about *severe to lethal injuries* that might occur if the instructions are not followed correctly.



DANGER

This combination of signal word and symbol warns you of dangerous situations which could lead directly to death or severe injuries.



2. For your safety

2.1. Proper use

Use in dental technology

The proper use of the “smart optics Vinyl Series” scanners is the optical three-dimensional measurement of human jaw models. The scanners can be used in the field of orthodontics and prosthetics for all kinds of reconstructions, as well as for archiving purposes.

Jaw models in occlusal relationship can be scanned with reference to cephalic presentation, as well as dental registrations (bite registrations) and dental casts (wax-up), and also reference bodies (scan bodies) screw-retained in the model.

Use as a universal scanner

The proper use of the “smart optics Vinyl Series” scanners is the optical three-dimensional measurement of objects with a maximum size of 80 × 60 × 85 mm (XYZ). The maximum weight of the objects must not exceed 0.938 kg. The scanners can be used for the production of, for example, tools, jewelry or toys as well as to test the accuracy of replicas.

Material characteristics

The scanners of the Vinyl series scan materials with a dry, opaque surface of white, saffron, gold, blue, beige, yellow and pink color. Reflective or dark surfaces can be scanned if they are previously treated with 3D scan spray. Moveable parts of the models must be able to be immobilized, so that they do not change their position during scanning.



Improper use

The scanners of the Vinyl series are not designed to scan models made of transparent materials, models of non-dimensionally stable or unstable materials or living organisms.

The scanners of the Vinyl series are not suitable for use in an environment heavily burdened by emissions (e.g. dust or paint). Their use in a private environment is also excluded.

smart optics strongly advises to avoid any other than the proper use. smart optics assumes no liability for damages due to an improper use of the scanner and/or non-observance of the safety instructions indicated in these operating instructions.

2.2. General safety instructions

User qualification

Users who set up, commission or operate a smart optics scanner require special knowledge for the safe operation of the scanner. This knowledge can be acquired by means of the following measures:

- Read and follow these operating instructions, in particular the instructions concerning setup, commissioning and cleaning of the scanner.
- Participate in an induction or training course.
- Comply with local laws, regulations, occupational safety and accident prevention rules concerning your scanner's workplace.
- Make sure that all devices and cables pass the periodic safety checks for electrical appliances. Replace damaged devices and cables immediately. Make sure that the technical specifications of power cables are adequate.

Constructive protective measures

The scanner has been developed and manufactured in compliance with the applicable safety standards and with the greatest possible care to ensure safe operation and to protect the user against injuries.

A fuse to protect the device from overvoltage is integrated into the device.



Protection against injuries

Despite the protective measures included in the design, some residual risks that might lead to injuries cannot be excluded. In this section you will learn what measures you can take to protect yourself and other people.

Electric shock and short circuit



WARNING

Risk of injury due to electric shock Fire hazard due to short circuit

A technical defect of the cable or of individual components of the scanner can cause an electric shock or a short circuit. This can result in a fire.

- ▶ Make sure that no electrical equipment can come into contact with water/moisture. Should this however happen at some time, disconnect the power plug immediately. Dry the affected parts with a soft microfiber cloth.
- ▶ Do not work with defective devices or cables under any circumstances.
- ▶ Operate electrical equipment only at the recommended operating temperatures.
- ▶ Only use the supplied cable or the corresponding spare parts.
- ▶ If electrical devices are not used over a longer period, such as overnight, turn them off and disconnect the power plug from the socket.

Magnetic fields



WARNING

Health hazard due to magnetic fields

The scanner and its accessories include magnetic components. Magnetic fields can be health-damaging.

- ▶ Persons with implants, in particular heart pacemakers, may only operate the scanner and its accessories with express medical permission.



Stripe light



WARNING

Health hazard due to stripe light

The scanner works with stripe light. Constant visual contact with stripe light can trigger epileptic seizures, migraine or similar conditions.

- ▶ Individuals suffering from such conditions should close or cover the scanner during operation.

Blue light



WARNING

Health hazard due to LED light with high blue content

Recent studies show that light with a high blue content can lead to permanent retinal damage or contribute to it. White LED light also has a high blue content. Users should therefore avoid prolonged visual contact with white or blue LED light.

- ▶ The scanner emits white light or blue light with each measurement. Close or cover the scanner during operation.
- ▶ Wearers of glasses can protect their eyes with glasses with a blue light filter.

Falling



CAUTION

Risk of falling due to packaging materials

The scanner is extensively packaged for protection against transport damages. The packaging can be an obstacle during setup and can cause falls.

- ▶ Do not leave packaging materials lying on the ground.
- ▶ Before transporting, move all obstacles out of the way.



Carrying

**CAUTION****Risk of injury due to incorrect carrying**

Due to its size and weight, we recommend that two people should unpack and set up the scanner. In particular, shorter individuals can be injured if they lift or carry the scanner by themselves without any help.

- ▶ Two people should lift the scanner out of its packaging.
- ▶ Two people should carry the scanner.
- ▶ Carry the scanner with the lid closed.
- ▶ To transport the scanner, always grasp it by the bottom corners, never by the lid.

Crushing

**CAUTION****Risk of injury due to the lid or the mechanical parts of the scanner**

You can get crushed by the lid or the mechanical parts of the scanner.

- ▶ Always hold the lid by its handle to open or close it. If you act sideways and move the lid, you will crush your fingers between the lid and the housing.
- ▶ Lift the lid gently. Otherwise it will fall down again, because there is no resistance in the closing mechanism.
- ▶ Always open the lid up to the stop.
- ▶ Only put your hands inside the scanner when the axes have stopped. Should the axes not stop at the end of a scanning process, turn off the scanner and disconnect the power plug.



Entanglement

**CAUTION****Injury due to entanglement of clothing, jewelry or hair**

Loose clothing, jewelry or long hair can get entangled in the lid or the mechanical parts of the scanner. Due to motion, objects and hair can get entangled inside the scanner. This can lead to injury.

- ▶ Do not wear any loose garments such as shawls and ties, or jewelry like long necklaces, at the scanner's workplace.
- ▶ Comb your hair into a firm pigtail, for example.
- ▶ However, should a piece of clothing, hair or jewelry get entangled among the moving parts of the device, turn the scanner off immediately. Disconnect the power plug before removing the entangled part.

Protection against material damages

Despite the protective measures included in the design, some residual risks that might lead to material damages (loss of data or damage to devices) cannot be excluded. In this section you will learn what measures can be taken against material damages.

Optics/Electronics

**NOTE****Damage to optical and electronic components due to touching, humidity, dirt and cleaning**

The optical and electronic components in the interior of the scanner are highly sensitive. Any touch, as well as dirt, moisture and cleaning agents can damage them.

- ▶ Do not touch any optical and electronic components,
- ▶ Protect the optical and electronic components against soiling by closing the lid or covering the scanner.
- ▶ Never use the 3D scan spray inside the scanner.
- ▶ If the optical or electronic components have to be cleaned, do not do it yourself. Please contact your reseller.



Carrying

**NOTE****Damage to the scanner due to incorrect carrying**

The lid and the front upper corners are not suitable to be used as carrying handles. If you carry the scanner by the lid, it can come off and the scanner will fall and get damaged. If you reach into the front upper corners, you can damage sensitive components, especially the camera and the sensor.

- ▶ Carry the scanner with the lid closed (with the exception of Vinyl Open Air).
- ▶ To transport the scanner, always grasp it by the bottom corners, never by the lid nor the front upper corners.
- ▶ During transport place a protective film over the lid so that it cannot open.

Cleaning agents

**NOTE****Damage to surfaces due to unsuitable cleaning agents**

Paper towels, coarse cotton cloth, detergents, polishing paste, etc. leave scratches on the sensitive surfaces.

- ▶ Only use the recommended materials for cleaning.

Moisture

**NOTE****Material damages due to moisture**

Constant contact with moisture can damage sensitive materials.

- ▶ Only operate the scanner at a dry workplace.
- ▶ Avoid any contact with water/moisture. Should this however happen at some time, disconnect the power plug immediately. Immediately wipe off any water/moisture using a soft microfiber cloth.



Climate

**NOTE****Measuring errors due to unsuitable climatic conditions**

The scanner is designed solely for use inside dry, closed rooms. Precise measurement results are only achieved by the scanner under suitable climatic conditions. Too much heat causes measurement errors and overheating of the scanner. Overheating can permanently damage the scanner.

- ▶ Only operate the scanner at temperatures of 18°C - 30°C.
- ▶ Only operate the scanner in low humidity conditions.
- ▶ Avoid direct sun exposure at the workplace.
- ▶ Reduce cold, heat and high humidity, e.g. through the use of air conditioners or sun protection.

Reflections

**NOTE****Measuring errors due to reflections on the measured object**

Strong extraneous light leads to unwanted reflections on the measured object. This affects the accuracy of the measurements.

- ▶ Select a workplace away from a window or not affected by high levels of artificial lighting.
- ▶ If no other workplace is available, scan with the lid closed. If you are using Vinyl Open Air, cover the opening during the scanning process, e.g. with light-tight foil.

Vibration

**NOTE****Measuring errors due to vibrations**

The surface on which the scanner is placed must not vibrate. Vibration will cause inaccurate measurement results.

- ▶ Place the scanner on a sturdy, stable base able to support at least twice the weight of the scanner, i.e. 2 x 23 kg.
- ▶ Stabilize the base by means of a strutted under frame or by attaching it to a stable wall.



Calibration

**NOTE****Inaccurate measurements due to failure to calibrate or use of a damaged calibration model**

The measuring accuracy of the scanner is only guaranteed if the scanner is calibrated. This operation requires the use of a calibration model and the associated default values.

The calibration model can be mechanically damaged. This can only be tolerated in the border area.

- ▶ Perform the calibration of the scanner after commissioning, after transporting it and whenever the software asks you to do so during operation.
- ▶ Only start the procedure when the values registered in the software match the values of the calibration model.
- ▶ Check whether the calibration model is damaged at a central location.
- ▶ Only use the calibration model if it is in perfect condition.

Model fastening

**NOTE****Damage to the scanner and the models due to missing or incorrect fastening**

Due to the motion of the axes inside the scanner, unsecured or incorrectly secured models will fall down during the scanning process.

- ▶ Do not place any objects on top of or inside the scanner.
- ▶ Never place unfastened models inside the scanner.
- ▶ Only use the included object holder or approved accessories to fasten models.
- ▶ When fastening occlusal models with rubber bands, only use stable, unused rubber bands. Thin or porous rubber bands can tear.
- ▶ Always fasten models on the flexible object holder and the multiDie adapter using adhesive pads made of modeling clay.
- ▶ Only place stump models prepared with metal pins inside the multiDie adapter.
- ▶ However, should a model still fall down, turn off the scanner immediately. Then remove the model or all broken pieces from the interior of the scanner.



Adhesive materials



NOTE

Damages to models due to unsuitable adhesive materials

Models, object holders and the scanner get soiled or are even damaged through the use of adhesive tape, instant glue or similar products.

- ▶ Only fasten models using adhesive pads made of modeling clay.

Articulators



NOTE

Damages to the scanner and models due to incorrectly positioned articulators

Articulators are not to be fastened inside the scanner. This is possible because articulators can be scanned with reduced axis motion.

- ▶ Only place an articulator inside the scanner when the software asks you to do so.
- ▶ Always place an articulator with the front side first inside the scanner.
- ▶ Always place an articulator with all legs resting on the system plate.
- ▶ Always leave the lid open (except in the case of Vinyl Open Air)
- ▶ Remove an articulator immediately when the software asks you to do so.
- ▶ However, should an articulator still fall down, turn off the scanner immediately. Then remove the articulator or all broken pieces from the interior of the scanner.

USB cable



NOTE

Data loss due to a too long USB cable

The transfer of data between the scanner and the PC is affected by the length of the USB cable.

- ▶ Only use the supplied USB cable or an original spare part with the corresponding length (max. 2 meters).



Magnetic fields



NOTE

Data loss due to magnetic fields

The scanner and its accessories include magnetic components. Metal-containing technical devices and data carriers, e.g. credit cards, can be impaired in their function or even permanently damaged through contact with magnets.

- ▶ Make sure there is an adequate distance between metal-containing technical devices/data carriers and the magnet.

Response in case of a defect

You must not work with a defective system. Damage to the scanner, its accessories or a faulty function have occurred with high probability if:

- parts have been visibly damaged
- one or more of the moving axes continue to rotate or rotate in an uncontrolled way
- the calibration procedure fails
- measuring errors occur despite performing all work steps
- the software displays an error message.

- ▶ Follow the instruction in an error message.
- ▶ Check the connections. If applicable, replace the USB slots.
- ▶ End the software, switch off the scanner and the PC and restart the system.
- ▶ Check whether the software is installed correctly.
- ▶ Check the calibration data.
- ▶ Follow the instruction for device maintenance.
- ▶ Update your system. Check whether all important Windows updates have been installed.
- ▶ Ensure that your computer is free of viruses and malware.
- ▶ Allow the execution of dental Scan in your virus protection software.
- ▶ If none of these measures solve the problem, repeat with another computer to exclude a computer fault.
- ▶ If the problem also occurs with the other computer, refer to your reseller to clarify the cause of the fault.

Chapter 5.3



dental Scan installation

Chapter 15

Chapter 16



2.3. Symbols on the device

Warnings



Warning against hand injuries

This symbol refers to the lid or the closing mechanism of the scanner. If a body part enters the scanner opening, there is a risk of crushing. Always exercise care when reaching into the scanner to place the object holder.



Electrical voltage warning

This sign warns of electrical voltage inside the scanner. The rear cover of the scanner may only be removed by skilled personnel if the mains plug has been disconnected from the mains.



Do not touch

This symbol refers to the calibrated optical system. This must never be touched or cleaned as it could be damaged in the process.

Other



CE label

The CE label on the type plate documents that the European directives that are applicable to the device were complied with at the time of issue of the CE certificate.

EMC labelling

EN 55011 Class A

The electromagnetic compatibility of the device was checked for compliance with the limit values according to the European standard and the measuring methods for radio interference of industrial, scientific and medical high frequency devices. Labelling as "Class A" states that the device meets the standard for commercial applications.



Fuse

Symbol for an overcurrent protection device, installed in a mains connection, suitable for AC voltage 100 - 240 Volt and a frequency of 50/60 Hertz.



USB

Symbol for a USB connection, also for a camera connection.



Protective grounding

Symbol for connection to an external conductor to protect against electric shock in the event of a fault or connection of protective grounding (mass).



On/Off switch

Symbol for a switch to turn the device on and off.



3. Scope of delivery

The scope of delivery includes the following components:

Vinyl Open Air (90351)	Vinyl (90334)	Vinyl High Resolution (90400)
1 scanner – Touchscreen – White light LED – 1.3 Mpx camera	1 scanner – Touchscreen – Front lid – White light LED – 1.3 Mpx camera	1 scanner – Touchscreen – Front lid – Blue light LED – LED status bar – 2.8 Mpx camera
	Accessory case: 1 object holder with knurled screw 1 object holder, flexible, with large plate 1 multiDie adapter 1 Triple Tray® impression holder 2 packs of adhesive pads, extra-strong* 1 calibration model 1 data carrier	Accessory case: 1 object holder with knurled screw 1 object holder, flexible, with large plate 1 multiDie adapter 1 Triple Tray® impression holder 2 packs of adhesive pads, extra-strong* 1 calibration model 1 data carrier
Accessory box: 1 object holder with knurled screw** 1 calibration model 1 data carrier 1 power cable 1 USB cable	Accessory box: 1 power cable 1 USB cable	Accessory box: 1 power cable 1 USB cable

* UHU patafix PROPower or a comparable brand product made of removable, reusable adhesive glue pads

** To be able to use Vinyl Open Air for all project types, the required optional accessories can be purchased additionally.



Contents of the data carrier

Vinyl	Vinyl High Resolution	Vinyl Open Air
Calibration data dental Scan software with the modules:	Calibration data dental Scan software with the modules:	Calibration data dental Scan software with the modules*:
<ul style="list-style-type: none"> – secondDie – multiDie – multiCase – Monochrome texture Scan – Color texture Scan – Triple Tray® impression Scan – Universal mode 	<ul style="list-style-type: none"> – secondDie – multiDie – multiCase – Monochrome texture Scan – Color texture Scan – Triple Tray® impression Scan – Universal mode 	<ul style="list-style-type: none"> – secondDie – Monochrome texture Scan – Color texture Scan – Universal mode
Manuals (PDF):	Manuals (PDF):	Manuals (PDF):
<ul style="list-style-type: none"> – Scanner Operating Manual – dental Scan Installation Manual & User Manual 	<ul style="list-style-type: none"> – Scanner operating manual – dental Scan Installation Manual & User Manual 	<ul style="list-style-type: none"> – Scanner Operating Manual – dental Scan Installation Manual & User Manual

* Additional modules available for purchase (optional accessories).

Packaging

The packaging consists of the following components:

- pallet base
- bottom insert with foam protection
- accessory box
- bag (protective cover for the scanner)
- foldable wooden box
- foam insert
- foam pad for the front (Vinyl Open Air only)
- accessory case or box (depending on the model)
- inner lid with handling holes and foam protection
- outer lid



Optional accessories

In the case of Vinyl and Vinyl High Resolution, all components are already included in the standard scope of delivery. The exception being articulators (not an accessory) as well as adapter plates for articulators (chargeable accessory).

The functionality of Vinyl Open Air can be expanded by purchasing accessories.

You can purchase spare parts and chargeable accessories from your reseller.

Item number	Item name	Description
90404	PC Dell Precision 3630 CTO	High-performance computer with preinstalled software
90073	3D calibration model	Replacement or additional item
90082	Object holder with knurled screw	Replacement or additional item
90350	multiDie adapter	Replacement or additional item
90242	Occlusion clamp	Aid for the occlusion of non-articulated jaw models
90352	Triple Tray® Impression Holder	Replacement or additional item
90358	Object holder, flexible, with large plate	Replacement or additional item
90345	Adapter plate for articulated single jaw models suitable for SAM® AXIOSPLIT®	Additional item



Item number	Item name	Description
90346	Adapter plate for articulated single jaw models suitable for GAMMA® Reference	Additional item
90370	Adapter plate for articulated single jaw models suitable for Whip Mix Denar®	Additional item
90371	Adapter plate for articulated single jaw models suitable for KaVo PROTAR®	Additional item
144042	Handmade dust cover	Additional item

For safety reasons, please use only the replacement or additional items mentioned here. For parts that are not listed as replacement items, e.g. cables, please replace them with commercially available products with the same technical specifications.

Chapter 18

PCs must meet the technical specifications.



Activation Code

Activate the optional modules in the software that may require special accessories for their use. Further information is given in the dental Scan user manual.



Supported articulator systems

Articulators are available at specialist dental dealers, but cannot be purchased from smart optics as accessories for the scanner.

All conventional articulators can be used for vestibular scans with articulated occlusion models. Condyle-related measurements are possible with the articulators of the following manufacturers:

- AMANN GIRRBACH Artex®
- Baumann Dental Artist/arTO®
- SAM® AXIOSPLIT®
- GAMMA® Reference
- Whip Mix Denar®
- KaVo PROTAR®

Other articulators can be used for mean value measurements.



4. Device components

4.1. Front view

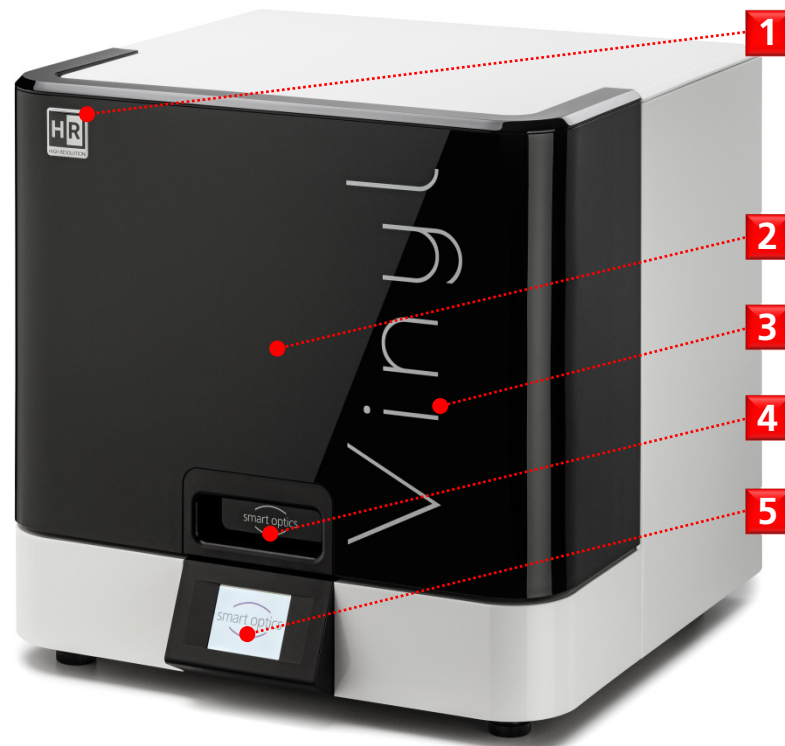

CAPTION

- 1 HR label (only for Vinyl High Resolution)
- 2 Lid (not included for Vinyl Open Air)
- 3 Device name
- 4 Handle (black or silver (matte) depending on the model/series)
- 5 Touchscreen



Detailed view of the touchscreen



CAPTION

- 1** Starting status (logo): Operation from the PC possible
- 2** Hibernation (screen saver) Operation from the PC possible
- 3** Operating status: Start button and process display
 - Start button: Operation from the device possible
 - Process display: The device is working, no user action possible



4.2. Internal view

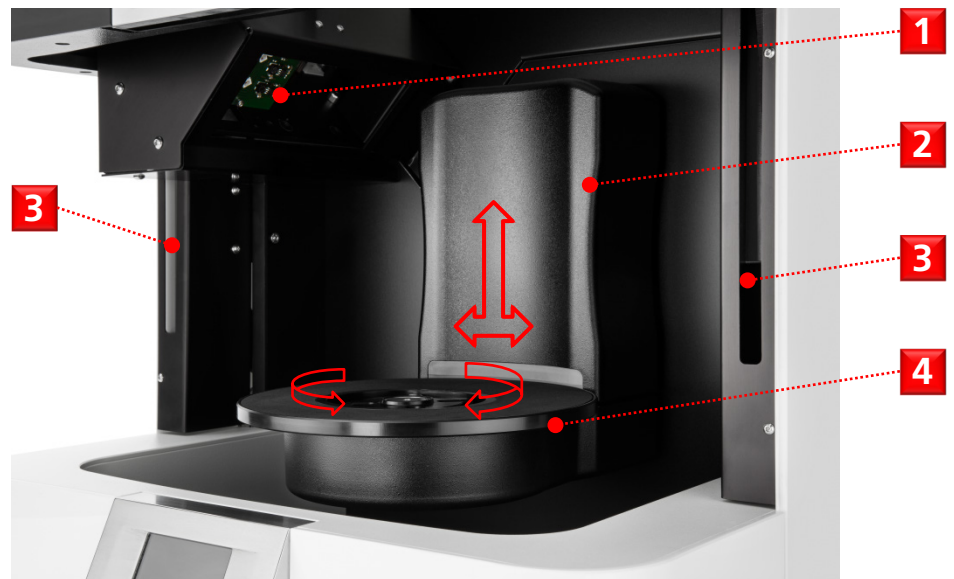

CAPTION

- 1 Optics (camera and 3D sensor)
- 2 Swivel axis (electromotive lateral movement 0 - 45°)
Z-axis (electromotive up and downwards movement 0 – 30 mm)
- 3 Guide rails for the lid
(not present in the Vinyl Open Air variant)
- 4 Rotary axis (electromotive rotation up to 315°)
System plate with Adesso Multisplit base plate



Detailed view of the system plate

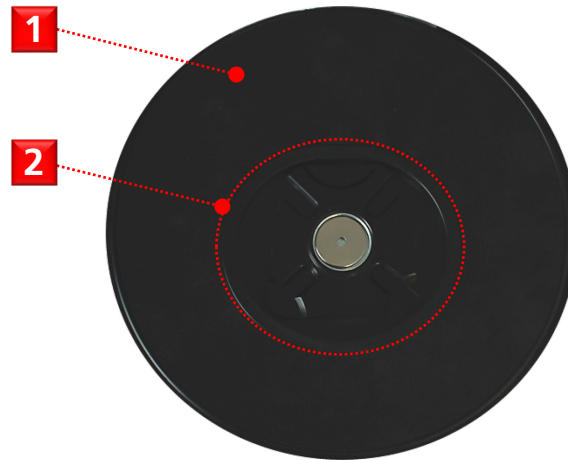

CAPTION

- 1 Turntable with non-slip rubber mat for the placement of articulators
- 2 Adesso® Multisplit base plate for mounting object holders, adapter plates and Multisplit mounting plates

Detailed view of camera, sensor and LED

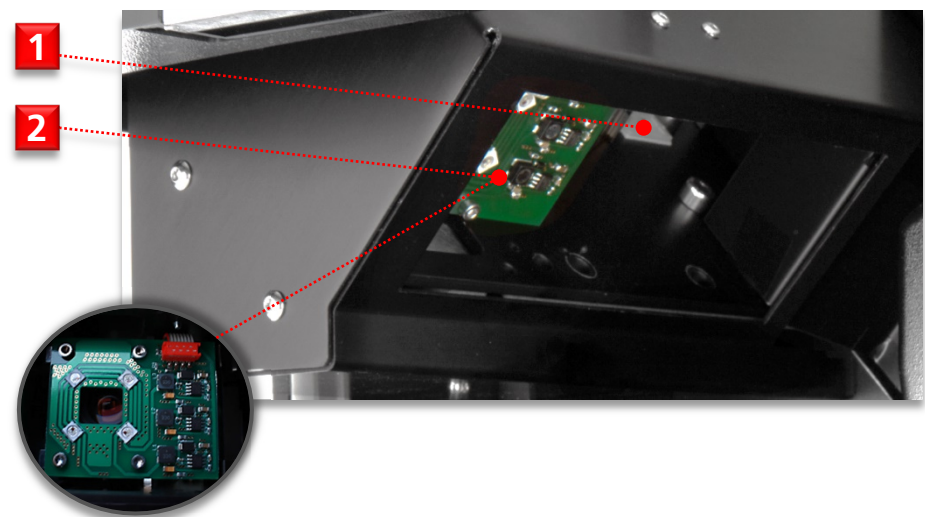

CAPTION

- 1 LED (white light or blue light (only for Vinyl High Resolution))
- 2 Optical system (camera and sensor) (high resolution for Vinyl High Resolution)



Detailed view of the status-LED (only for Vinyl High Resolution)

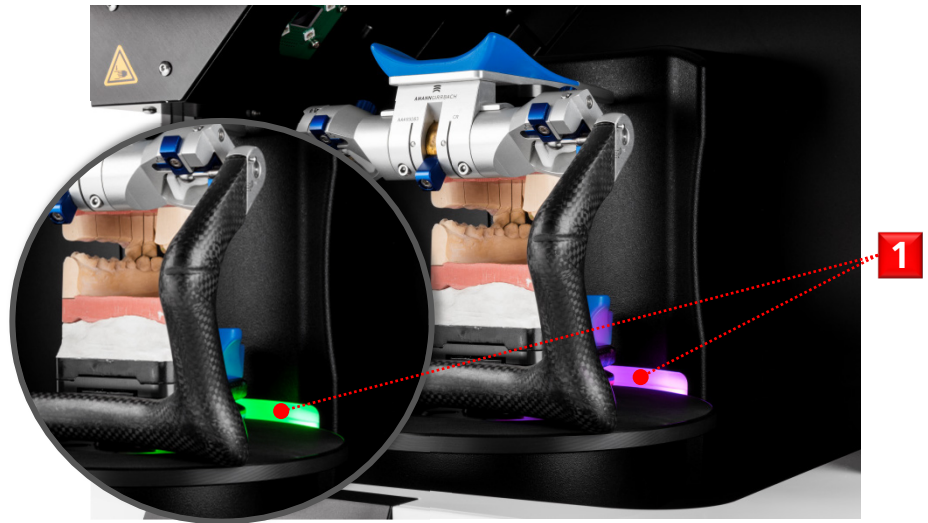

CAPTION

Status LED on the swivel axis

- Purple Hibernation (equivalent to the logo or screen saver on the touchscreen)
- Green Operation (corresponds to the start button and the process display on the touchscreen)

4.3. Views of the accessories (standard scope of delivery)



Accessory case with foam insert

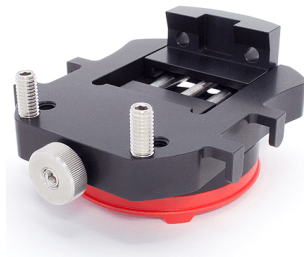

Object holder with knurled screw



Flexible object holder with large plate, fixing with adhesive pads



multiDie adapter, fixing with adhesive pads



Triple Tray® Impression Holder



Adhesive glue pads, extra-strong (Example image)



Calibration model (Example image)



Power cable



USB cable



Data carrier (Example image)



4.4. Connections and type plate (rear view)



CAPTION

- 1 ON/OFF switch
- 2 Functional grounding
- 3 USB connection for device control and camera
- 4 Mains connection with fuse

Type plate

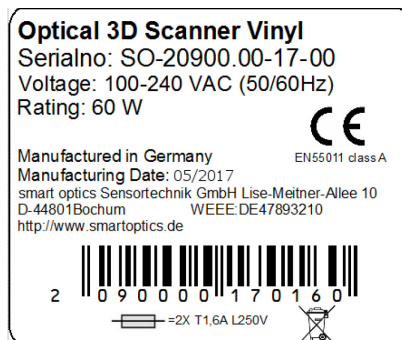

3D sensor serial No.
SO-20254.00-17-022

The type plate with technical information such as serial number of the device, place and date of manufacture is located on the rear.

The serial number of the 3D sensor is given on a separate label.



5. Setup and commissioning of the scanner

Chapter 20 You will find a short guide to this chapter in the appendix “Short Guide to Commissioning”

5.1. Choosing a workstation

Observe the safety instructions!

Chapter 2

- ▶ When choosing a workstation, please note that the Vinyl Series scanners are EMC Class A devices suitable for use in a commercial environment.

Chapter 18

- ▶ Choose a stable work desk that is big enough to allow the scanner to be connected to a PC. The weight of the scanner is 23 kg and its setup dimensions are 455 × 430 × 420 mm or, with its lid open, approximately 455 × 660 × 470 mm (W x H x D).
- ▶ Ensure easy access to the rear as this is where the ON/OFF switch is located.



- ▶ Ensure that there are enough and sufficiently fused mains sockets for all the devices. After consultation with an electrician, you can use an approved extension cable, a multiple power socket and a socket adapter (additional electrical devices not included in the scope of delivery).

5.2. Unpacking the scanner

Observe the safety instructions!

Chapter 2

The scanner is delivered in a foldable wooden box. The wooden box is equipped with an impact and tilt indicator (outside) and clad with a foam transport protection (inside).



TIP

Keep the packaging for possible transport or return. The original packaging is precisely adapted to the scanner and thus offers the best protection against transport damage. If necessary, you can request packing instructions from smart optics.

- ▶ Check the outer packaging for visible damage immediately on receipt.



- ▶ If an indicator indicates a careless storage or even any shipping irregularities or if damage is evident on the packaging, please inform the delivery company and your reseller. Follow the instructions provided by the delivery company and reseller before continuing to unpack the device.
- ▶ Transport the scanner in the packaging as close to the workstation as possible.



To unpack, you need a flat-tip screwdriver and combination pliers.

- ▶ Bend back the metal tabs at the top and bottom of the wooden box. For this purpose, carefully press the screwdriver between the tab and the wood until a gap is created.
- ▶ Grasp the tab with the pliers.
- ▶ Bend the tab about 180° (those at the top upwards; those at the bottom downwards).
- ✓ When all metal tabs are in a vertical position, they will fit through the slots at the top and bottom.

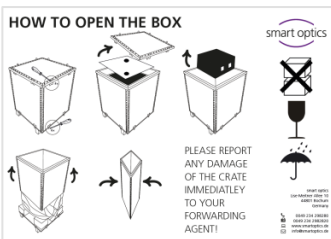

Unpacking instructions



- ▶ Lift the lid and the inside covering.
- ▶ Remove the accessory case or box and place it aside. Depending on the model/series, the accessories may be on top or below the scanner.
- ▶ Remove the foam board.



- ▶ Pull the wooden box upwards.
- ▶ Press the wooden box together from two opposite corners.



Carrying by two persons (recommended)



TIP

Due to the dimensions and weight smart optics recommends carrying by two persons.

Never hold it by the lid.

In the case of Vinyl Open Air, never hold it by the front upper corners because sensitive technical components are placed there.

The protective foil prevents incorrect gripping or unintentional opening of the lid.



Position of person 1



Position of person 2

- ▶ Position yourself with a second person to the right and left of the scanner.
- ▶ Place one hand each under the front and rear corner of the scanner.
- ▶ Lift the scanner simultaneously.
- ▶ When carrying, incline the scanner slightly backwards.
- ✓ In this position the lid remains secured.

Carrying by one person (not recommended)

Position of the person



- ▶ Position yourself behind the scanner.
- ▶ Grasp with one hand on the side and as far forward as possible under the scanner.
- ▶ Lift the scanner so that it is slightly inclined backwards when carrying.
- ✓ In this position the lid remains secured.



Setting the scanner down

- ▶ Set the scanner down carefully and in a straight position at the place of installation.
- ▶ Remove the protective foil.
- ▶ If necessary, take the accessory box out of the base insert.

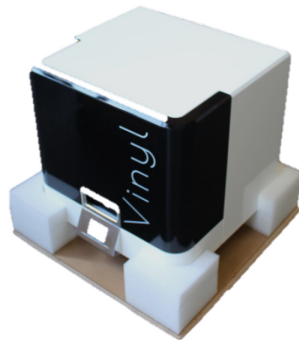

Chapter 3

- ▶ Immediately check the scanner and the accessories for completeness and any visible damage.
- ✓ If the scope of delivery is not complete or if one of the supplied parts shows visible damage, inform your reseller immediately. Follow the instructions provided by the reseller before continuing with the setup.



5.3. Connecting the scanner

Observe the safety instructions!

Chapter 2

Chapter 4.4

The scanner requires a mains connection and a PC connection. The scanner does not work without a software.

The connections are located on the rear of the scanner.

- ▶ Connect the rectangular type B plug of the USB cable to the USB port of the scanner.
- ▶ Connect the device plug of the power cable to the corresponding mains socket on the scanner.

CABLE CONNECTIONS OF THE SCANNER

- 1 USB connection
- 2 Mains connection

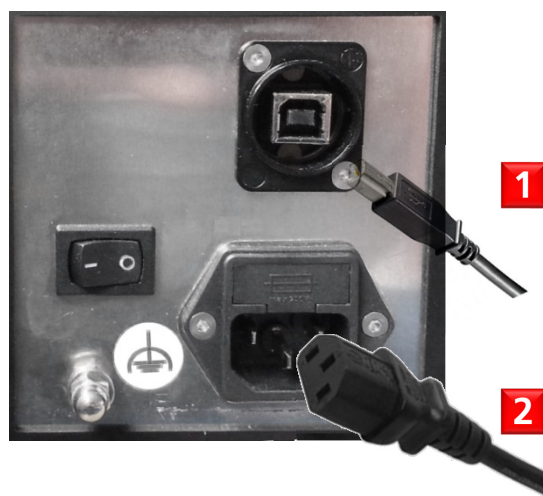

- ▶ Connect the mains plug of the power cable to the mains. It is not necessary to use an adapter to adjust the voltage as an AC-DC device is integrated in the scanner.



- ▶ Connect the flat type A plug of the USB cable to a free USB port of the PC.



dental Scan installation

- ✓ The scanner is operational.
- ▶ Switch on the scanner using the power switch.
- ✓ The power switch is in position I.
- ✓ The touchscreen displays the starting status (logo).
- ▶ Install dental Scan now. You will find comprehensive information in the dental Scan installation manual.

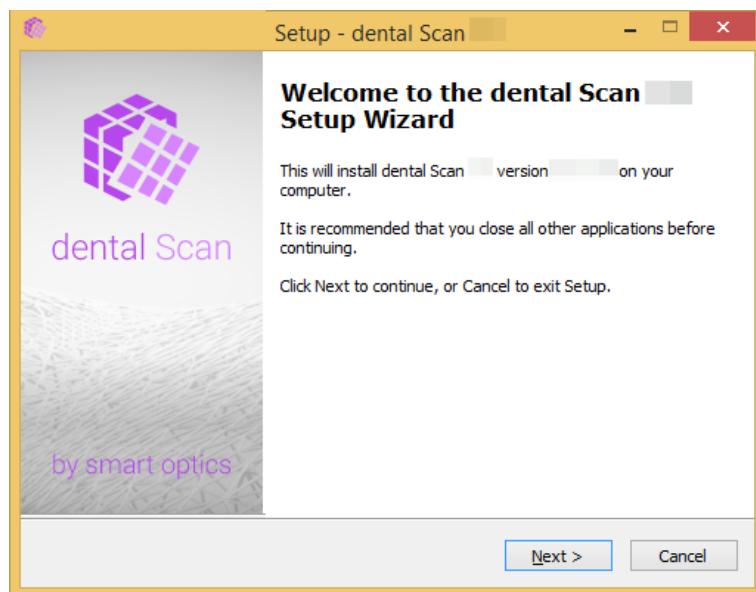



5.4. Opening and closing the scanner

Observe the safety instructions!



The big lid of Vinyl/Vinyl High Resolution can remain open during operation.

smart optics recommends closing the lid whenever possible (especially during periods of inactivity) to protect sensitive components. If you are using the Vinyl Open Air model, you can cover the opening when necessary, e.g. with light-tight foil.

- ▶ Hold the handle at the lower edge of the lid.
- ▶ Lift the lid gently up to the stop.
- ▶ Release the lid in this position.

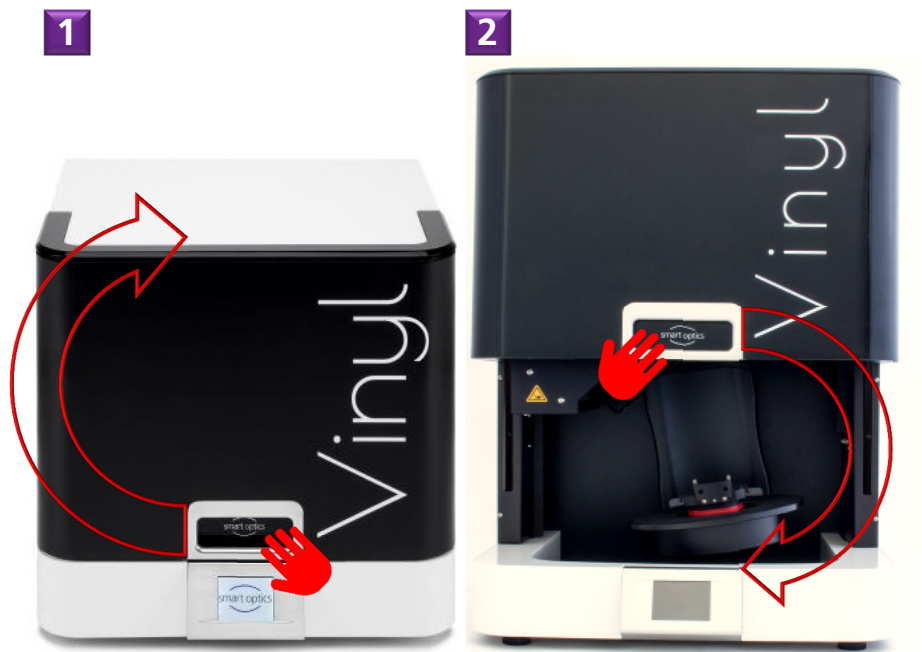

- ✓ The lid will stay in a vertical position without being fastened.
- ▶ To close the lid, grip the handle.
- ▶ Gently move the lid to the end position



6. The object holder system

6.1. Overview

Observe the safety instructions!



Chapter 2

The extensive object holder system of the Vinyl series allows you to securely fasten and insert jaw models, partial models, tooth stump models, Triple Tray® impressions and occlusion models.

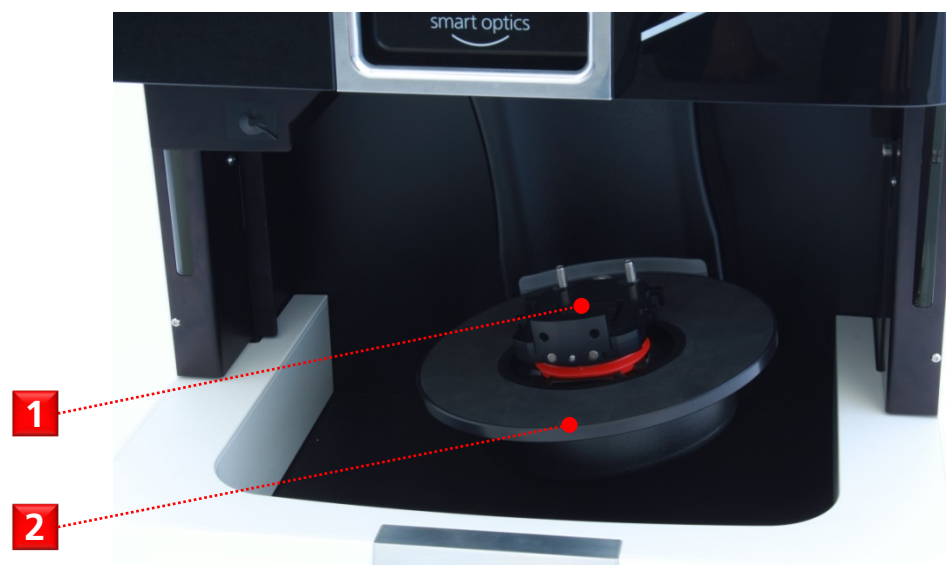

CAPTION

- 1 Object holder: in this case the model with knurled screw for single jaw models
- 2 Base plate with non-slip rubber mat and Multisplit base for object holder, adapter plates and Multisplit mounting plates



Multisplit base plate

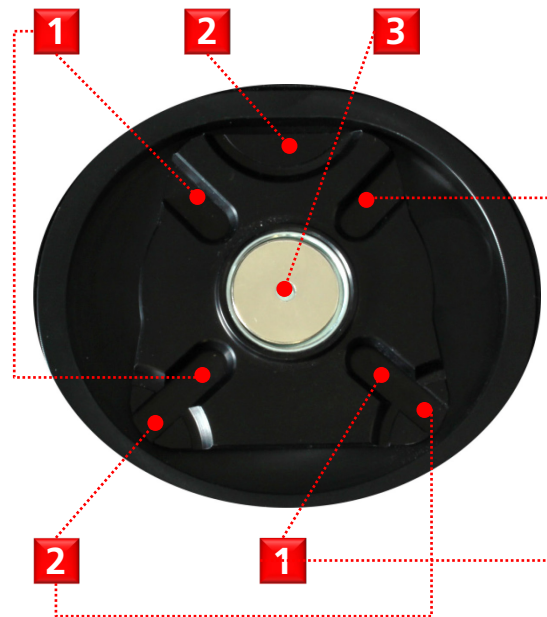

CAPTION

- 1 Contact points for object holders and adapter plates ("Ovals")
- 2 Contact points for Multisplit mounting plates ("Corners")
- 3 Magnetic adhesive disk for mounting object holders, adapter plates and Multisplit mounting plates

6.2. Matting the surface with 3D scan spray

Reflective or dark surfaces must be matted with 3D scan spray before being scanned. smart optics recommends that only products with extra-fine grain size and suitability for dental technology be used, for example the scan spray offered as part of the accessories.

- ▶ Follow the instructions of the manufacturer regarding application, safety and material compatibility.
- ▶ If the 3D scan spray has to be sprayed in the work area, close the scanner or cover it previously. This way, you protect the sensitive optical and the electronic components from damaging dusts. Never spray into the inside of the scanner.
- ▶ Fasten the model or object to the object holder before spraying.
- ▶ Spray according to the instructions as targeted as possible onto the model or object.



- ▶ When inserting, make sure not to touch the spray layer.
- ▶ After scanning, remove the spray residue from the object holder and model or object. Follow the instructions of the manufacturer for this as well.

7. Positioning of a single jaw model

You have several options for fastening single jaw models.



Chapter 7.1 – 7.3

- Inserting a jaw model with a Multisplit mounting plate
- Inserting a jaw model with an adapter plate
- Inserting a jaw model with an object holder

7.1. Inserting a jaw model with a Multisplit mounting plate

Observe the safety instructions!

Chapter 2

No additional fastening is required for jaw models plastered on a Multisplit mounting plate.

You can place the Multisplit mounting plate directly on the Multisplit base plate of the scanner. This option exists for the articulator systems AMANN GIRRBACH Artex® and Baumann Dental Artist/arTO®.

- ▶ Plaster the jaw model onto the Multisplit mounting plate according to the manufacturer's instructions. Make sure to insert a magnetic adhesive disk into the Multisplit mounting plate.



- ▶ Place the Multisplit mounting plate on the Multisplit base plate of the scanner. Ensure that the protrusions ("Corners") on the underside of



the Multisplit mounting plate fit into the recesses of the Multisplit base plate.

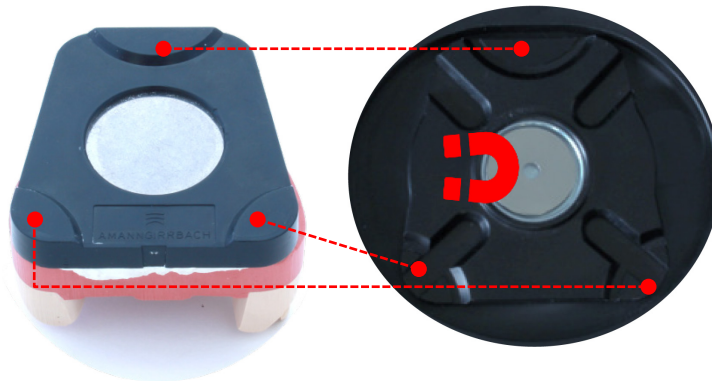

- ✓ The Multisplit mounting plate will adhere to the magnet of the Multisplit base plate.
- ✓ The Multisplit mounting plate fits correctly when the plates are exactly congruent. Additional securing of the plastered jaw model is not necessary.

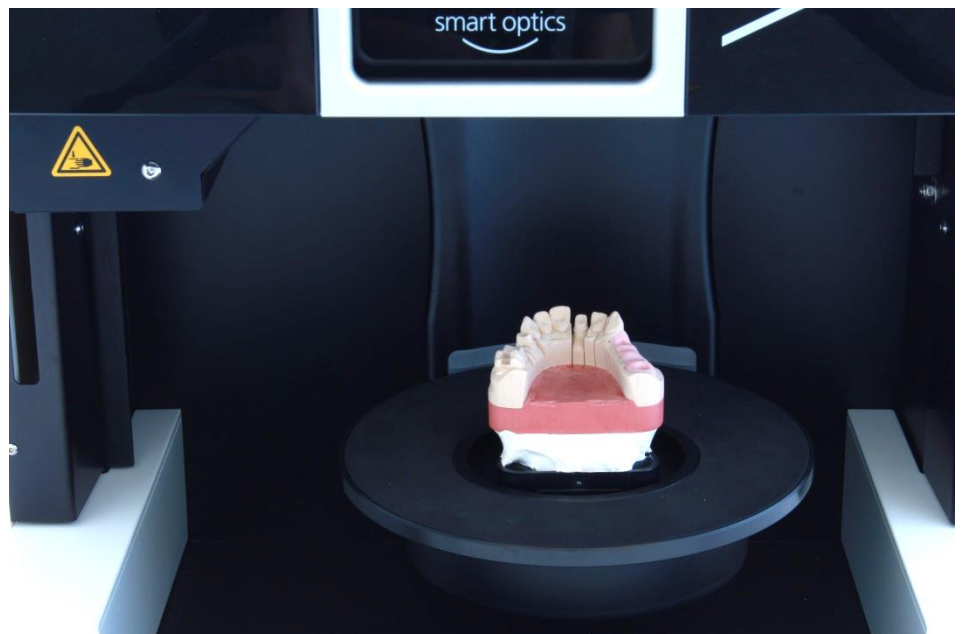



7.2. Inserting a jaw model with an adapter plate

Overview

Using an adapter plate as spacer, you can place the mounting plates of articulated jaw models on the Multisplit base plate of the scanner.



Adapter plates are available as optional accessories for the following articulator systems:



- SAM® AXIOSPLIT®
- GAMMA® Reference
- Whip Mix Denar®
- KaVo PROTAR®



Chapter 7.1

No adapter plates are required for AMANN GIRRBACH Artex® and Baumann Dental Artist/arTO®.

CAPTION

- 1 Magnet
- 2 Recess ("Corner")
- 3 Protrusion ("Oval")

Top (in this case: SAM® AXIOSPLIT®)

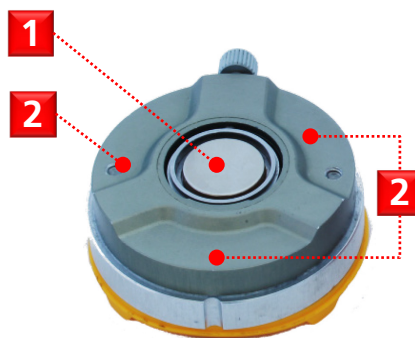

Bottom (in this case: SAM® AXIOSPLIT®)

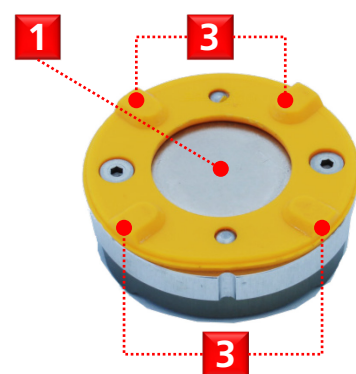

The mounting plates of the corresponding articulator fit the top of the adapter plate. The underside fits to the Multisplit base plate inside the scanner.



Placing a mounting plate on the adapter plate

Observe the safety instructions!

Chapter 2

- ▶ Plaster the jaw model onto the mounting plate according to the manufacturer's instructions. Make sure to insert a magnetic adhesive disk into the mounting plate.
- ▶ Place the mounting plate on the adapter plate such, that the protrusions ("Corners") on the underside of the mounting plate fit into the identically shaped recesses of the adapter plate.

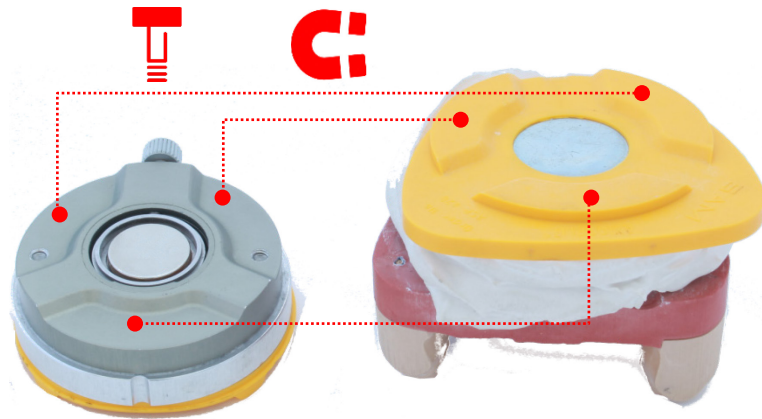

SAM® AXIOSPLIT®

- ✓ The mounting plate will adhere to the magnet of the adapter plate.
- ✓ The mounting plate fits correctly when the plates coincide exactly.
- ▶ The magnetic adhesive disk in the adapter plates for SAM® AXIOSPLIT® is retained with a fixating screw. Ensure that this is tightened firmly.



- ✓ Additional securing of the plastered jaw model is not necessary.

Inserting an adapter plate

Observe the safety instructions!

Chapter 2

- ▶ Hold the adapter plate from the side of the Adesso Split® plastic plate.
- ▶ Insert the adapter plate into the scanner.
- ✓ The protrusions ("Ovals") on the underside of the plastic plate engage with the recesses of the Multisplit base plate.

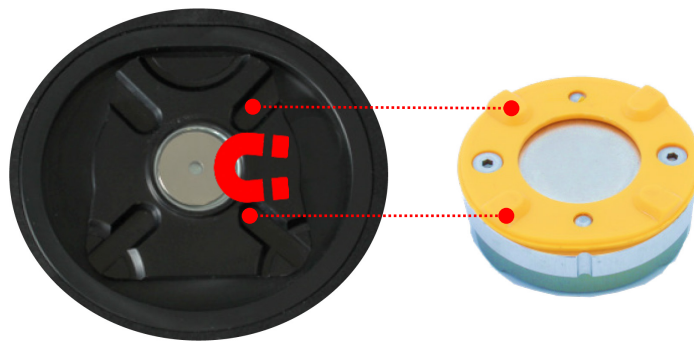

- ✓ The adapter plate will adhere to the magnet of the Multisplit base plate.
- ▶ Check whether the adapter plate can be shifted easily. If this is the case, correct the fit until the adapter plate fits securely.

Removing the adapter plate

- ▶ Hold the adapter plate on two sides; if necessary, use both hands (not the mounting plate).

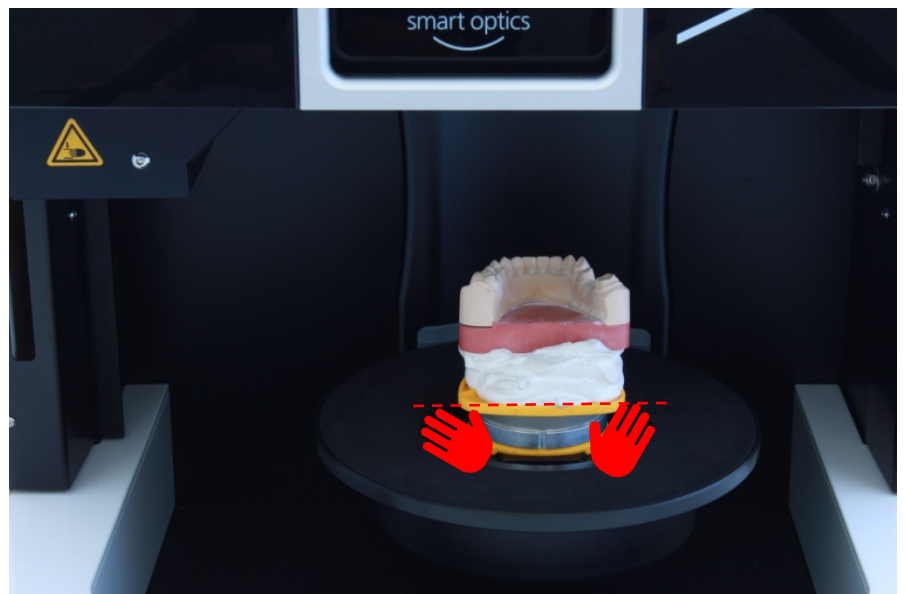

- ▶ Carefully pull the adapter plate upwards. A certain amount of force is required due to the magnetic attraction.
- ✓ The adapter plate is released from the Multisplit base plate.



Service position

TIP

The axes can be moved unintentionally during removal. For this situation, dental Scan features a function to drive the axes back into the service position.

7.3. Inserting a jaw model with an object holder

Overview

Object holder with knurled screw

CAPTION

- 1 Rear
- 2 Front
- 3 Floating stop
- 4 Hook
- 5 Threaded pins
- 6 Knurled screw with clockwise thread
- 7 Adesso Split® plastic plate with adhesive disk

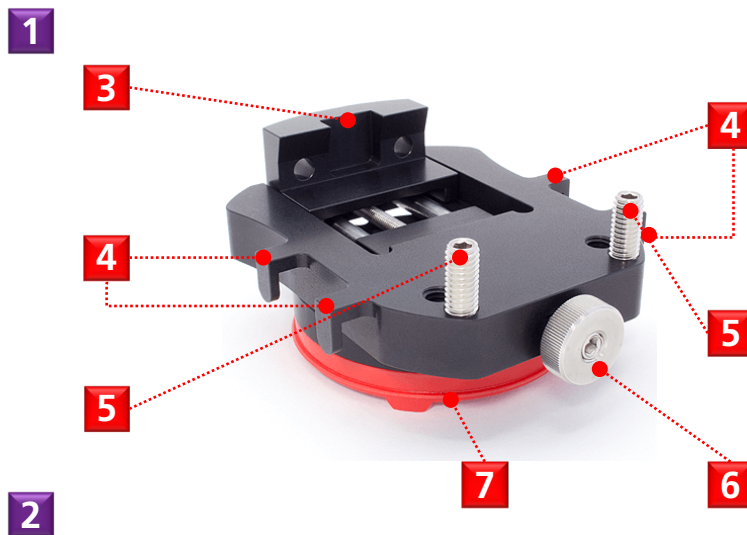

CAPTION

- 1 Front
- 2 Rear
- 3 Top
- 4 Magnetic points
- 5 Adesso Split® plastic plate with adhesive disk

Flexible object holder

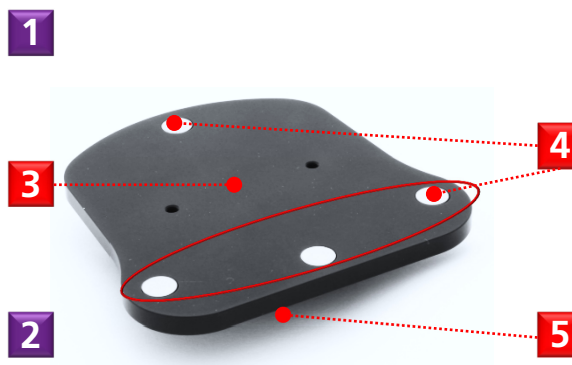

The flexible object holder for Vinyl Open Air is available as an optional accessory from your reseller. It is included in the scope of delivery for Vinyl and Vinyl High Resolution.



Fastening a jaw model onto an object holder

The object holders for the scanners of the Vinyl series serve to fasten a jaw model mechanically. This method is to be applied to jaw models which are not plastered.

Object holder with knurled screw

Different sizes of jaw models can be fastened securely to the object holder with the knurled screw.

Observe the safety instructions!



Chapter 2

- ▶ Place the jaw model (upper or lower jaw) with the bottom side on the object holder.
- ▶ If required, loosen the knurled screw to increase the space.
- ✓ The anterior teeth point in direction of the knurled screw.
- ▶ Press the jaw model gently against the threaded pins.
- ▶ Tighten the knurled screw.
- ✓ The jaw model is placed correctly if it is flush with the floating stop and the threaded pins.



Flexible object holder

Jaw models (upper or lower jaw) can be securely fastened on the flexible object holder with the big plate. To fasten them, you require adhesive glue pads.



Chapter 3

Two packs of adhesive pads are included in the scope of delivery. You can purchase replacements from office suppliers if required.

- ▶ Cover the topside of the plate with adhesive pads. You should use at least three pads for complete jaw models.
- ▶ Place the jaw model (upper or lower jaw) with the bottom side on the adhesive pads.
- ✓ The anterior teeth point in direction of the single magnetic point (1).

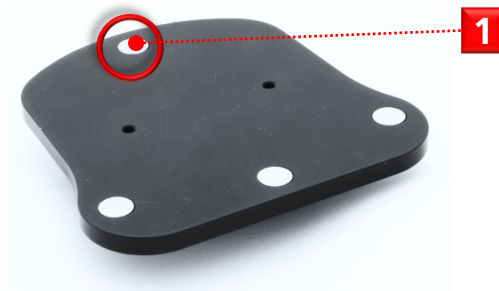

- ▶ Press the jaw model firmly.
- ✓ The jaw model is placed correctly when it does not extend beyond the magnetic points.
- ▶ Tilt the object holder carefully to the right and left.
- ✓ The jaw model is placed correctly when it does not slip.
- ▶ Should the jaw model slip, use additional adhesive pads.

Inserting the object holders

The described procedure is the same for both object holders.

Observe the safety instructions!

 Chapter 2

- ▶ Hold the object holder from the side.
- ▶ Place the object holder with the front side or the knurled screw facing forwards inside the scanner.
- ✓ The protrusions (“Ovals”) on the underside of the object holder engage with the recesses of the Multisplit base plate..
- ✓ The object holder will adhere to the magnet of the Multisplit base plate.

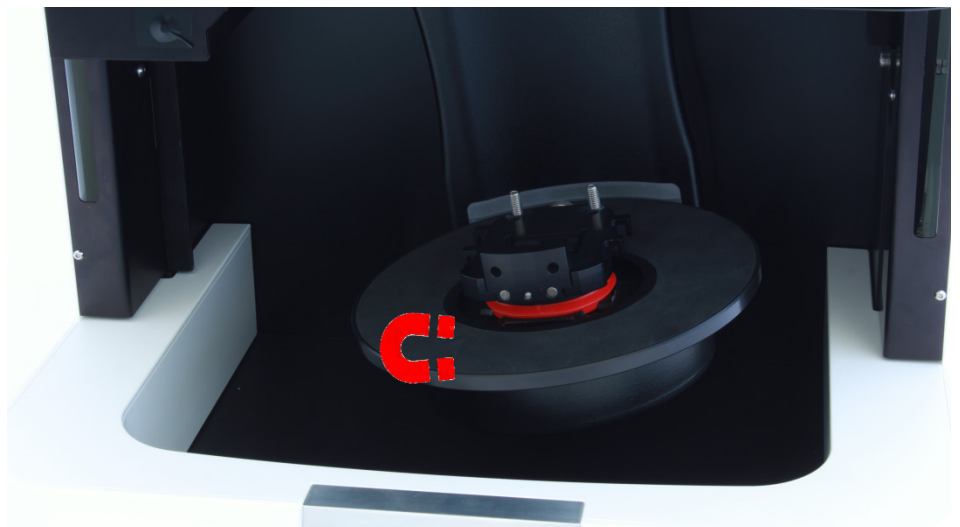



- ▶ Check whether the object holder can be shifted easily. If this is the case, correct the fit until the object holder fits securely.

Removing the object holder

The described procedure is the same for both object holders. To fasten a jaw model to the object holder, you should always remove the object holder from the scanner.

- ▶ Hold the adapter plate on both sides; if necessary, use both hands.
- ▶ Carefully pull the object holder upwards. A certain amount of force is required due to the magnetic attraction.
- ✓ The object holder is released from the Multisplit base plate.



Service position

TIP

Upon removal, the rotary axis may be moved unintentionally. For this situation, dental Scan features a function to drive the axes back into the service position.

7.4. Fastening gingiva, squeeze bites, scanbodies or wax-ups



- ▶ To scan gingiva, squeeze bites, scanbodies or wax-ups, fasten the small prosthetic parts to the jaw model according to the prosthetics manufacturer's instructions.
- ▶ Tighten the scanbodies firmly.
- ▶ Fasten the prepared jaw model to an object holder or a mounting plate for your articulator.
- ✓ As a rule, no further fixation is required. Loosely placed parts can be glued slightly in two places with a removable adhesive if required.



Chapter 7



8. Positioning of non-articulated occlusion models

You have various options for inserting an occlusion model into the scanner. The easiest method for non-articulated occlusion is to fasten the occlusion model to the object holder with knurled screw using a rubber band.

The flexible object holder is not suitable for this purpose.

Chapter 8.2

Alternatively you can use an occlusion clamp.

Chapter 9

For articulated occlusions you require an articulator.

8.1. Fastening an occlusion model with a rubber band

Observe the safety instructions!

Chapter 2

To fasten the upper and lower jaw in occlusion, you require a conventional rubber band of approx. 0.4 cm width and approx. 8.5 cm diameter. Alternatively you can use a crossed band. The length and strength of the rubber band varies depending on the jaw model. For this reason, always keep several different rubber bands available.

Rubber bands are not included in the optional scanner accessories. For safety reasons, use only new, robust rubber bands and replace these regularly.

- ▶ Place the upper jaw model on the lower jaw model in occlusion.
- ▶ Place the rubber band in cross form so that the top part of the upper jaw model so that an equally long loop hangs from each side.
- ▶ Guide the end of each rubber loop around the hooks on the side of the object holder.

Chapter 7.3



- ✓ The fastening is adequate if the upper jaw model cannot be tipped or shifted with slight pressure.
- ▶ If necessary, shorten the rubber bands by coiling over the hooks several times.



Alternatively, you can use two shorter rubber bands or a crossed band. Depending on the length and strength of the rubber bands used, alternative fastening methods are possible, e.g.:

- ▶ Place two shorter rubber bands at an angle over the jaw model.
- ▶ Guide one end each at the front and rear around one of the hooks on the side of the object holder.

If you are using a crossed band, you can only secure the jaw models to the object holder in occlusion.

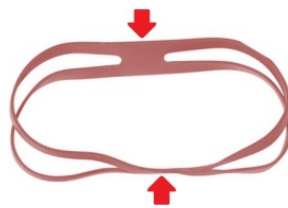

- ▶ Place the crossed band around the jaw models in occlusion such, that one crossed part is on the top and one on the bottom and that the two partial bands are stretched on the side.

Page 52

- ▶ Secure the connected jaw models on the object holder.
- ▶ Guide the laterally stretched rubber bands around the hooks on the object holder.



8.2. Fastening of an occlusion model with an occlusion clamp

Observe the safety instructions!



With the aid of the smart optics occlusion clamps you can fasten the upper and lower jaw model easily and conveniently in non-articulated occlusion. The occlusion is closed in this manner and remains firmly joined, even during mechanical movement.



The occlusion clamp for non-articulated occlusion is an optional accessory for the scanners of the Vinyl series and can be obtained from your reseller.

Overview

CAPTION

- 1 Locking screw
- 2 Mounting rod
- 3 Pressure fitting with ball knob
- 4 Metal pins
- 5 Plug-in connection

Occlusion clamp without object holder

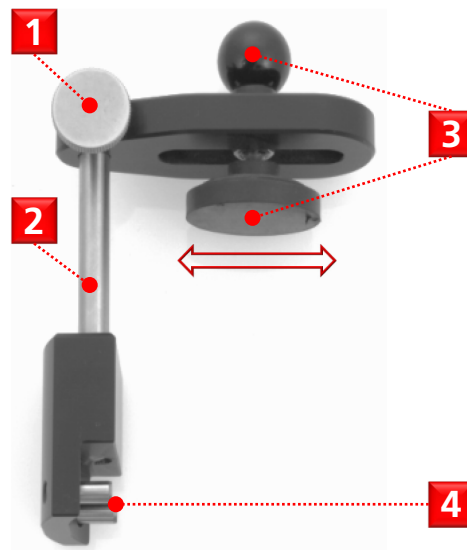

Occlusion clamp with fastened object holder



Fastening



- ▶ Fasten first the lower jaw model to the object holder with the knurled screw.
- ▶ Place the upper jaw model on the lower jaw model in occlusion.
- ▶ Loosen the ball knob (3) as much as necessary to allow the pressure fitting to be moved forwards and backwards. Fasten the occlusion clamp to the floating stop of the object holder by pushing the metal pins (4) into the holes of the floating stop on the object holder (5).
- ▶ Hold the occlusion model firmly.



- ▶ Push the pressure fitting **(3)** on the ball knob as central as possible over the upper jaw model.
- ▶ Loosen the locking screw **(1)** until the fastening rod **(2)** of the pressure fitting can be moved up and down.
- ▶ Hold the ball knob and press the upper jaw model onto the lower jaw model.
- ▶ Carefully tighten the screw **(1)** and the ball knob **(3)** until the occlusion model can no longer be moved.
- ✓ The occlusion model is clamped.



- ▶ Now place the object holder inside the scanner as usual.



9. Positioning of articulated occlusal models

With the help of an articulator, you can establish the articulated occlusion of the upper and the lower jaw model.

You can place any articulator without any further accessories inside the scanner for vestibular scans.

Condyle-related measuring is possible with the following articulators:

- AMANN GIRRBACH Artex® (without adapter plate)
- Baumann Dental Artist/arTO® (without adapter plate)
- SAM® AXIOSPLIT®
- GAMMA® Reference
- Whip Mix Denar®
- KaVo PROTAR®

Articulators are available at specialist dealers, but not from smart optics as an accessory for the scanner.

9.1. Positioning of an occlusal model with an articulator

Overview

CAPTION

- 1 Front
- 2 Rear
- 3 Top support pin
- 4 Front support pin
- 5 Feet





Inserting the Articulator

Example
AMANN GIRRBACH Artex®

All articulators are to be handled in the same way, independently of type and manufacturer.



Observe the safety instructions!

Chapter 2

Service position

- ▶ Make sure that the occlusal model is correctly articulated.
- ▶ Remove the top support pin from the articulator.
- ▶ Also remove the front support pin, if possible.
- ▶ It is essential that you wait until the software asks you to insert the articulator. Only then is it ensured that the motion of the axes is minimal during the ensuing scanning procedure.
- ✓ The system plate of the scanner is driven into the horizontal service position. If this is not the case, dental Scan features a function allowing to drive to this position.
- ▶ Grasp the articulator by the rear struts with both hands.
- ▶ Place an articulator with the front side forward inside the scanner.
- ✓ The front side of the articulator points to the rear side of the scanner. A different orientation is not permitted.

CORRECT:

FALSE:



- ✓ The articulator stands free and does not touch the scanner.



- ▶ Place the articulator on the system plate so that **ALL** feet are resting on the rubber mat. Place the articulator in a central position.
- ✓ The articulator stands centrally on the system plate. A different position is not permitted.
- ✓ The rubber mat is anti-slip. No further fastening is necessary.



TIP

Always leave the lid open during an articulator scan.

Removing the articulator

- ▶ Wait until the software reports the end of the scanning procedure.
- ▶ Remove the articulator as soon as the software asks you to do so.
- ▶ Grasp the articulator as before by the rear struts.
- ▶ Lift the articulator horizontally out of the scanner.
- ▶ Now you can proceed with the workflow in the software.



TIP

Upon removal, the rotary axis may be moved unintentionally. For this situation, dental Scan features a function to drive the axes back into the service position.



Service position



10. Positioning tooth stump models with the multiDie adapter

You can position up to twelve tooth stump models individually with the multiDie adapter.

You can use the multiDie adapter for the two modules multiDie and multiCase.



The multiDie adapter for Vinyl Open Air is available as an optional accessory from your reseller. It is included in the scope of delivery for Vinyl and Vinyl High Resolution.

Overview

CAPTION

- 1 Adesso Split® plastic plate with adhesive disk
- 2 Slots
- 3 Flat side (front)

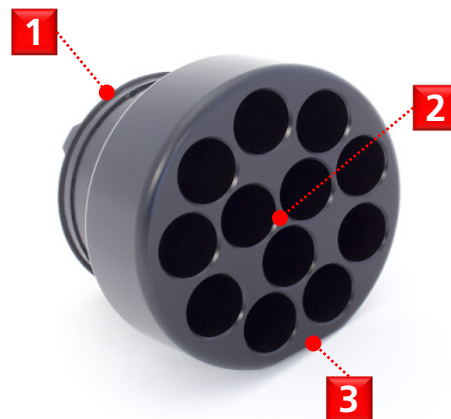

Numbering of the slots

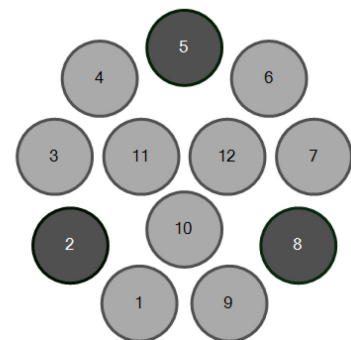

Fastening tooth stump models

To ensure that the tooth stump models sit firmly on the multiDie adapter, you require the adhesive pads as fixing material.

Two packs of adhesive pads are included in the scope of delivery. As replacement you can use commercially available adhesive glue pads. These should be extra strong and removable, not coloring nor hardening.

- ▶ Fill all slots with adhesive pads.
- ✓ The glue material should fill the slots up to their edge, but not protrude from them. The glue material can remain in the slots permanently.
- ▶ Insert the metal pins of the tooth stump models into the slots.



 Release (multiDie)
Project definition multiCase

TIP

If you only insert of 1, 2 or 3 tooth stump models, the slots 2, 5 and 8 must be used. For all further tooth stump models you can choose the slots freely.

Correct fastening

The prepared tooth stump models are fastened correctly if:

- they are straight (not tilted)
- they have no contact with their neighbor
- they lie on the multiDie adapter – in other words, insert the metal pins as deep as possible into the glue material
- they remain in their position when the multiDie adapter is rotated or tilted.

It is of advantage, but not a precondition, to insert the tooth stump models such that the buccal side faces outwards.

Inserting the Triple Tray® impression holder



Observe the safety instructions!

 Chapter 2

- ▶ Hold the multiDie adapter from the side.
- ▶ Place the multiDie adapter inside the scanner so that the flat side faces the front of the scanner.
- ✓ The protrusions (“Ovals”) on the underside engage with the recesses of the Multisplit base plate..



- ✓ The Triple Tray® impression holder will adhere to the magnet of the Multisplit base plate.
- ▶ Check whether the multiDie adapter can be shifted easily. If this is the case, correct the fit until the multiDie adapter fits securely.

Removing the Triple Tray® impression holder

- ▶ Hold the multiDie adapter from the side, if necessary, use both hands.
- ▶ Carefully pull the Triple Tray® impression holder upwards. A certain amount of force is required due to the magnetic attraction.
- ✓ The Triple Tray® impression holder is released from the Multisplit base plate.



Service position

TIP

Upon removal, the rotary axis may be moved unintentionally. For this situation, dental Scan features a function to drive the axes back into the service position.



11. Positioning of aTriple Tray® impression

The Triple Tray® impression holder allows you to position Triple Tray® impression trays inside the scanner.

You can use the Triple Tray® impression holder with the Triple Tray® impression scan module.



The Triple Tray® impression holder for Vinyl Open Air is available as an optional accessory from your reseller. It is included in the scope of delivery for Vinyl and Vinyl High Resolution.

Overview

CAPTION

- 1 Upper part
- 2 Lower part
- 3 Rear
- 4 Front
- 5 Magnetic adhesion point
- 6 Clamp with spring
- 7 Adesso Split® plastic plate with adhesive disk

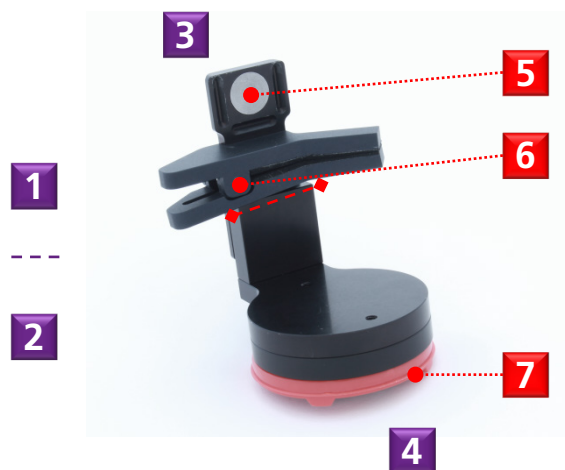

Fastening a Triple Tray® impression scan

Observe the safety instructions!



A Triple Tray® impression tray can be clamped quite easily in the Triple Tray® impression holder.

- ▶ Press the clamp on the broad side and keep it pressed.

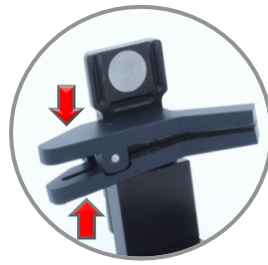

Inserting a Triple Tray® impression

- ✓ The opposite side is pressed apart.
- ▶ Turn the side of the Triple Tray® impression demanded by the software upwards.
- ▶ Insert the flat shaft of the Triple Tray® impression holder into the narrowest position between the open side of the clamp.
- ▶ Release the clamp.



Correct fastening

The Triple Tray® impression is fastened correctly if:

- it is clamped
- it is positioned parallel to the lower part of the Triple Tray® impression holder
- the impression to be scanned faces upwards.

Turning a Triple Tray® impression

To scan the other side of the Triple Tray® impression, turn the upper part without releasing the impression from the clamp.

- ▶ Separate the upper part from the lower part applying a little force.
- ✓ The magnetic contact is released.
- ▶ Turn the upper part so that the other side of the impression faces upwards.



- ▶ Press the lower magnetic point against the lower part.

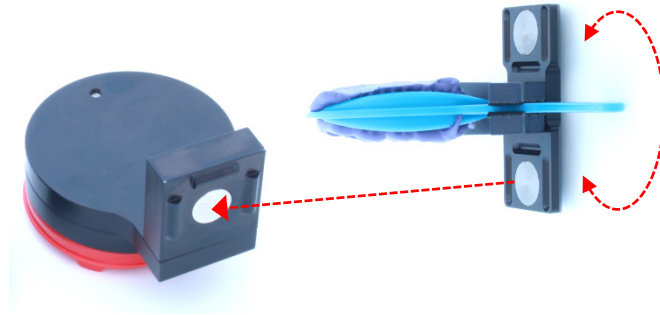

- ✓ The upper part will adhere magnetically to the lower part. The adhesive effect is reinforced by the grooves and braces.

Inserting the Triple Tray® impression holder



- ▶ Hold the Triple Tray® impression holder from the rear.
- ▶ Place the Triple Tray® impression holder with the impression facing forwards inside the scanner.
- ✓ The Triple Tray® impression holder will adhere to the magnet of the Multisplit base plate.
- ✓ The protrusions (“Ovals”) on the underside of the plastic plate engage with the recesses of the Multisplit base plate.
- ✓ The Triple Tray® impression faces to the rear of the scanner.

Correct ■
False ■

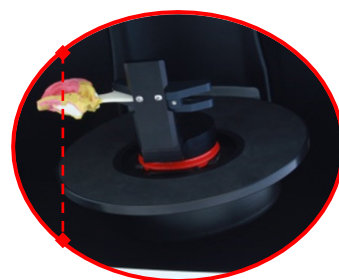
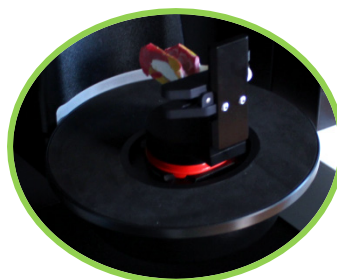



- ▶ Check whether the Triple Tray® impression holder can be shifted easily. If this is the case, correct the fit until the Triple Tray® impression holder is adhered securely.

Removing the Triple Tray® impression holder

- ▶ Hold the Triple Tray® impression holder by the lower part; if necessary, use both hands.
- ▶ Carefully pull the Triple Tray® impression holder upwards. A certain amount of force is required due to the magnetic attraction.
- ✓ The Triple Tray® impression holder is released from the Multisplit base plate.



Service position

TIP

Upon removal, the rotary axis may be moved unintentionally. For this situation, dental Scan features a function to drive the axes back into the service position.



12. Positioning objects (universal mode)

Scannable objects are very individual physical bodies. Thus, only general advice on correct positioning can be provided here. In principle, smart optics recommends using the flexible object holder for the Universal Mode.

CAPTION

- 1 Front
- 2 Rear
- 3 Top
- 4 Magnetic points
- 5 Adesso Split® plastic plate with adhesive disk

Flexible object holder

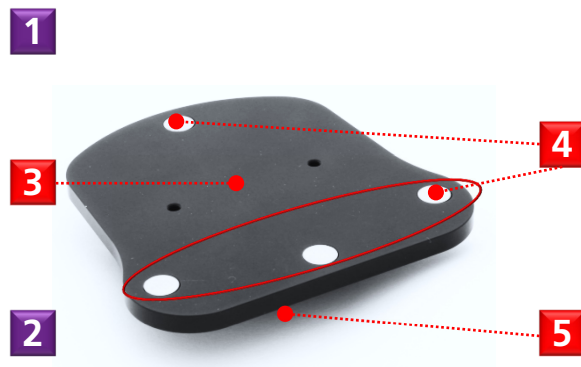

With this object holder, solid, opaque objects such as tools, jewelry or toys with a maximum size of 80 × 60 × 85 mm (XYZ) and a maximum weight of 0.938 kg can be scanned.

80 × 60 × 85 mm (XYZ)
0.938 kg

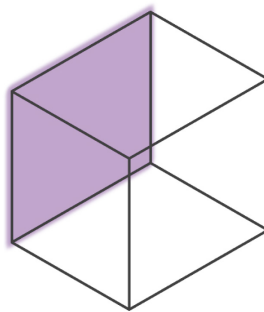

Page 26

The flexible object holder for Vinyl Open Air is available as an optional accessory from your reseller. It is included in the scope of delivery for Vinyl and Vinyl High Resolution.

Please note that the standard scope of delivery of Vinyl and Vinyl High Resolution includes one multiDie adapter and one Triple Tray® impression holder intended exclusively for dental applications.



Properties of scannable objects

Chapter 6.2

Glossy surfaces (such as metal) or very dark surfaces cannot be scanned. Reflections and lack of contrast to the scanner's interior make an accurate measurement impossible. Therefore, such objects should be matted with 3D scan spray.

Dimensional stability

Only objects that do not change their shape during scanning can be scanned. Make sure that moving parts are adequately immobilized.

Top and bottom

To fully digitize a three-dimensional object, it usually needs to be scanned from two sides. The second scan captures the bearing surface that was hidden during the first scan. In the simplest case, turn the object on the object holder. Depending on the shape of the object, it may be useful to choose a different fastening for the second side.

12.1. Fastening objects on the flexible object holder

Observe the safety instructions!

Chapter 2

Objects can be fastened securely on the flexible object holder with the big plate.



Chapter 7.3, 10, 11

TIP

Try out the best way to fasten an object.

Test the stability of the fastening outside the scanner using sideways and rotational movements to determine which object holder best fits an object. Create sample scans and compare the results.

So you can, for example, place jewelry instead of single-tooth models into the multiDie adapter or clamp them into the Triple Tray® impression holder. The object holder with the knurled screw can achieve good results with solid bodies having a wide, smooth underside. Please note that multiDie adapters and Triple Tray® impression holders can only support smaller, lighter weight items (<80 x 60 x 85 mm (XYZ), 0.938 kg).



Magnetic objects

Four magnetic points are placed on the top of the object holder. Each of the magnets measures: 10.0 Ø × 3.0 H mm. The adhesive force depends on the opposite pole and the environmental conditions and must therefore be checked on a case-by-case basis.

Magnetic points

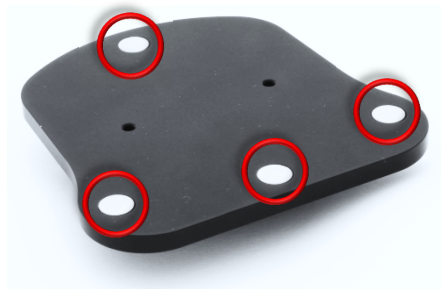

- ▶ Place a magnetic object on the plate so that it is held by the magnetic points.
- ▶ If the object does not cover the area between the magnetic points, you can enlarge the area with magnetic plates or magnetic tape (available as office supplies).
- ✓ The adhesive effect depends on the individual magnetization of the object and the inserted magnetic plates.

Non-magnetic objects

Chapter 3

Adhesive glue pads are necessary to fasten non-magnetic objects. Two packs of adhesive pads are included in the scope of delivery. You can purchase replacements from office suppliers if required.

- ▶ Cover the topside of the plate with adhesive pads. Different numbers of adhesive pads may be needed, depending on the size, weight and shape of the object. Knead several adhesive pads together and shape e.g. a plate or a pillow.
- ▶ Place the object with the underside on the adhesive pads.
- ▶ Align the front / main side of the object with the single magnetic point **(1)**.

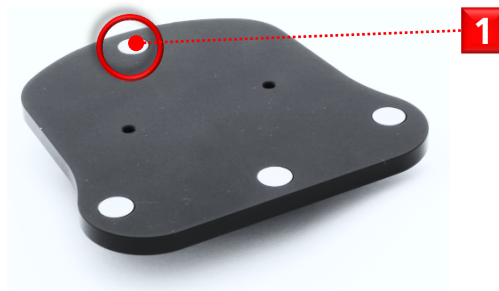

- ▶ Press the object firmly.
- ✓ The object is placed properly if it does not protrude beyond the magnetic points.
- ▶ Tilt the object holder carefully to the right and left.
- ✓ The object is placed correctly when it does not slip.
- ▶ If the object does slip, use more adhesive pads or alternatively test another object holder.

12.2. Inserting the object holder

Observe the safety instructions!



Chapter 2

The described procedure is the same for all object holders.

- ▶ Hold the object holder from the side.
- ▶ Place an object holder with the front side forward inside the scanner.
- ✓ The protrusions (“Ovals”) on the underside of the object holder engage with the recesses of the Multisplit base plate..
- ✓ The object holder will adhere to the magnet of the Multisplit base plate.

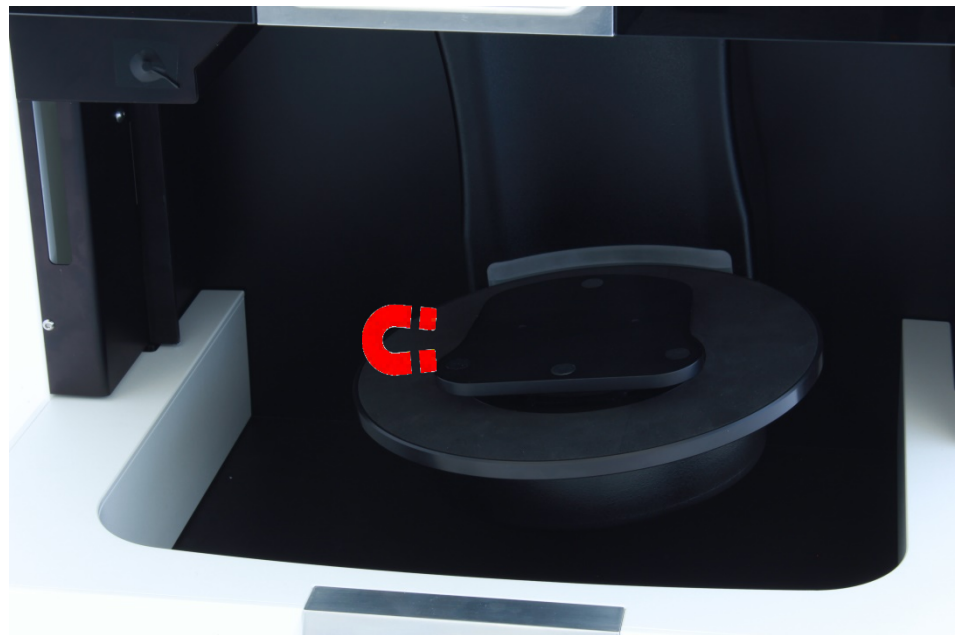

- ▶ Check whether the object holder can be shifted easily. If this is the case, correct the fit until the object holder fits securely.

12.3. Removing the object holder

The described procedure is the same for all object holders. To fasten an object to the object holder, you should always remove the object holder from the scanner.

- ▶ Hold the adapter plate on both sides; if necessary, use both hands.
- ▶ Carefully pull the object holder upwards. A certain amount of force is required due to the magnetic attraction.
- ✓ The object holder is released from the Multisplit base plate.



Service position

TIP

Upon removal, the rotary axis may be moved unintentionally. For this situation, dental Scan features a function to drive the axes back into the service position.



13. Positioning the calibration model

A calibration model is required to calibrate the scanner. A calibration model is included in the scope of delivery. Each calibration model is measured industrially and assigned these measurements.



TIP

If your calibration model is damaged and you are unsure whether this model can be used, your reseller will be pleased to advise you and provide you with a replacement if necessary.

It is recommended to have the calibration model always at hand during operation.

Overview

CAPTION

- 1 Top
- 2 Bottom
- 3 Depressions
- 4 Measured values
- 5 Model number

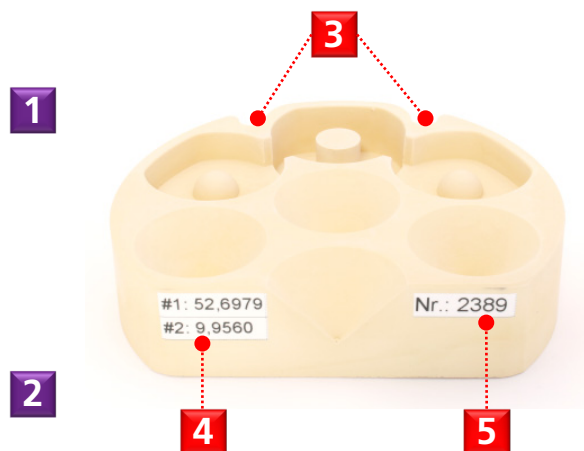



Inserting and removing the calibration model

Chapter 7.3

The calibration model is to be handled in the same manner as a single jaw model. To fasten it, you require the object holder with the knurled screw.

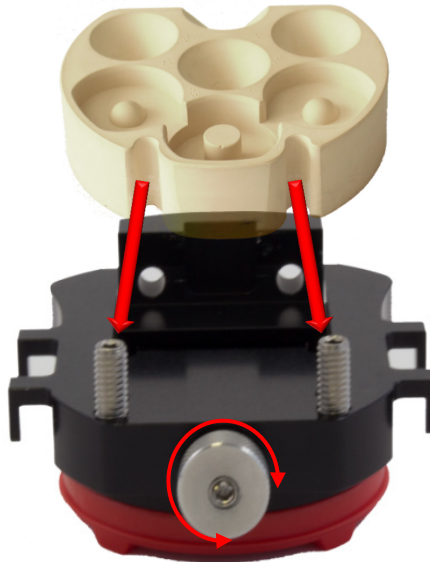

Observe the safety instructions!

Chapter 2

- ▶ If required, loosen the knurled screw to provide more room on the object holder.
- ▶ Place the underside of the calibration model on the object holder.
- ▶ Press the depressions of the calibration model slightly against the threaded pins of the object holder.
- ▶ Tighten the knurled screw.
- ✓ The calibration model is placed correctly when it is flush both at the front and the rear.
- ✓ The impression with the measured values faces the floating stop.
- ▶ Insert the object holder. When doing it, observe the software's messages.



Calibration

TIP

Information on calibration is provided in the dental Scan user manual.

Page 54

- ▶ Remove the object holder as usual.



14. Operating principle of the scanner



Use of dental Scan

TIP

Information on all scanning procedures, the setting options and the use of optional modules can be found in the dental Scan user manual.

The most important components of the scanner are the 3D sensor and a positioning mechanism.

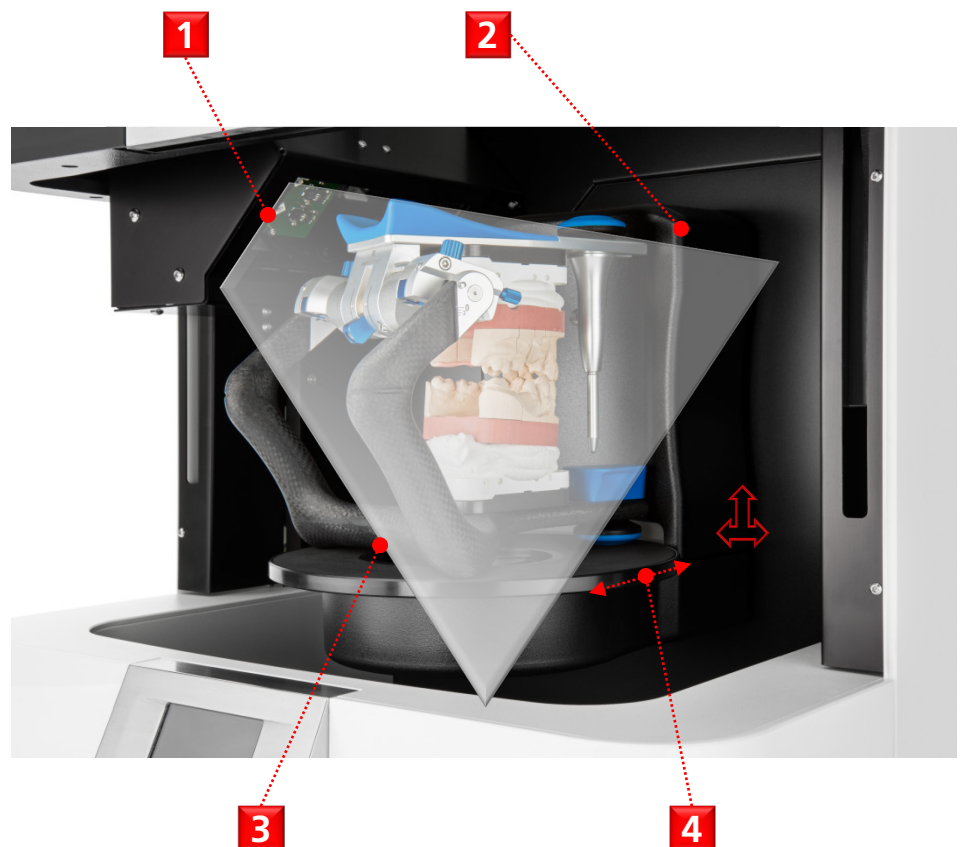

The positioning mechanism in the interior of the scanner consist of a rotary and swivel axis driven by an electric motor(4) as well as an automatic z-axis (2).

The freely rotating Multisplit base plate (3) positions the object to be measured with regard to the 3D sensor (1), which is located above the swivel axis.



The swivel axis moves the rotary axis with the object holder to the side so that the 3D sensor can capture the object to be measured from the side.

During a measurement, the 3D sensor projects a striped pattern onto the object being scanned.

The light stripes are generated with a white or blue LED light. A blue LED light is used in combination with a 2.8 Mpx camera, as it requires more brightness and sharper contrasts.

The camera records the striped pattern. With the aid of several camera images taken from different angles, dental Scan calculates a 3-dimensional image of the object.

14.1. Operation via touchscreen

The scanner is equipped with a touchscreen which allows you to start scanning processes. Operation via touchscreen is an alternative to a mouse click in the software.



Use of dental Scan

You can also control the scanner exclusively via the software. You will find further information in the dental Scan user manual.

The company logo is displayed after switching on the scanner with the software already running.



After starting the software with the scanner already switched on, an animated red circle will be displayed:



- ▶ When the software displays a prompt, a start button appears on the touchscreen.
- ▶ Follow the instructions given by the software.
- ▶ Press the button to start.



- ✓ The scanning process starts.
- ✓ While scanning, the animated red circle will be displayed, and when the procedure has finished, the company logo.
- ✓ After prolonged inactivity, the screen saver is activated automatically.





14.2. Switching between LR and HR mode

The software allows you to switch between the low-resolution mode and the high-resolution mode. This determines the level of detail of the subsequent measurements. Please note that very detailed measurements take longer. If this is not required for the current project, you can save time with the low-resolution mode.



The high-resolution mode and thus the switching option is only available for the Vinyl High Resolution.



Project definition,
settings, messages

Whether high or low resolution should be default is determined in the settings of dental Scan. However, you can switch between the modes for each project and every single scan. The exact procedure is described in the dental Scan user manual.

15. Device maintenance

The scanner is a delicate and sensitive optical device. To ensure trouble-free operation of the scanner, it is necessary to regularly follow the correct care measures.

Further maintenance measures by the user are not required.

Scanner calibration

The scanner is calibrated with the aid of the software. This procedure is necessary to ensure accurate measurements.



Calibration

Perform the calibration of the scanner after the first setup, every time after transporting it and whenever the software asks you to do so during operation. Follow the dental Scan user manual for this purpose.



Cleaning the scanner

Observe the safety instructions!



The scanner should be cleaned regularly during operation. However, never clean the optical or other electronic components.

If the optical or electronic components are soiled, please contact your reseller.

- Before cleaning
 - ▶ Switch off the scanner for safety reasons.
 - ▶ Remove the cable connections.
 - ▶ Remove the object holder.

- Materials
 - ▶ Use microfiber cloths which are expressly suitable for high-gloss surfaces. The material must be soft, smooth, lint-free and anti-static.
 - ▶ Always dampen the cleaning cloth with a glass cleaner.
 - ▶ Never clean sensitive surfaces with abrasives, polishing pastes or rough cloths.

- Cleaning
 - ▶ Clean the surfaces as well as the object holder, the system plate and the axes with the moistened cleaning cloth.
 - ▶ Clean the touchscreen without applying pressure.
 - ▶ Coarse dirt and debris can be removed from the scanner floor with a vacuum cleaner. Attach the crevice nozzle and set the vacuum cleaner to its lowest vacuuming level.



16. Faults and repairs

Chapter 2, Page 21

If a fault occurs, first follow the safety instructions concerning response to a defect. If the fault persists, contact your reseller to clarify the cause of the fault.

Only have repairs carried out by your reseller.

If you are looking for a reseller in your area, please use the contact form for Sales on our homepage www.smartoptics.de. Improper repairs can cause the scanner to stop working perfectly.

Warranty

smart optics accepts no liability for damages caused by improper repairs. Please note that in this case your warranty claim will also become void.

Serial numbers

If you have questions or complaints relating to your device, please have the serial number of your Scanner and the serial number of the 3D sensor at hand.

You will find these numbers on the rear of the device:

Type plate

Serial number of the scanner

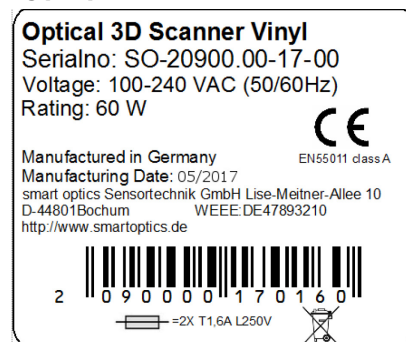

Label

Serial number of the 3D sensor

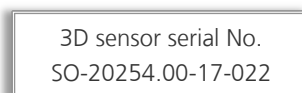



17. Environmentally-friendly disposal

The information in this chapter refers to EU directives and German law.

In non-European countries you must follow the corresponding national legislation for the disposal of packaging and electronic scrap.

You can prevent negative consequences for people and avoid harming the environment by the proper disposal of the device.

17.1. Disposal of the packaging

In accordance with the EU Directive 94/62/EC | 2015/720/EU and the German Packaging Act (VerpackG), you can return the packaging to your reseller for disposal in Germany. However, smart optics recommends that you keep the packaging in case you need it to transport the scanner or to send it back in the event of warranty claims.

17.2. Disposal of the device

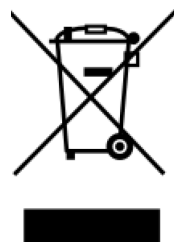

The devices marked with this symbol are subject to European Directive 2002/96/EC for WEEE (Waste Electrical and Electronic Equipment).

WEEE registration number of smart optics:
DE47893210

Electrical equipment must not be disposed of with domestic waste.

Please note that the scanner is a device that only serves for commercial or industrial use. Disposal via public waste management authorities is therefore not possible.

The device must be returned to the manufacturer for disposal. If you are resident within the area in which the EU directive applies you can also return the device to your reseller.



18. Technical specifications

	Vinyl Open Air	Vinyl	Vinyl High Resolution
FIRST PRODUCTION	2017	2017	2018
LAST HARDWARE UPDATE	2017	2017	2018
HOUSING			
Dimensions W × H × D			
mm closed	455 × 430 × 420	455 × 430 × 420	455 × 430 × 420
open	455 × 430 × 420	455 × 660 × 470	455 × 660 × 470
Weight	23 kg	23 kg	23 kg
Maximum load-bearing capacity (Universal Mode)	0.938 kg	0.938 kg	0.938 kg
Axes	1 Rotary axis 1 Swivel axis 1 Z-axis	1 Rotary axis 1 Swivel axis 1 Z-axis	1 Rotary axis 1 Swivel axis 1 Z-axis
Material	Metal, plastic (ABS HB PMMA)	Metal, plastic (ABS HB PMMA)	Metal, plastic (ABS HB PMMA)
Housing color	black-white (highly glossy)	black-white (highly glossy)	Black-white (highly glossy)
Handle and display frame color	silver matte	silver matte	black matte
Lid	No	Yes	Yes
Touchscreen	Yes	Yes	Yes
ON/OFF switch	Toggle switch, rear	Toggle switch, rear	Toggle switch, rear
Status LED	No	No	Yes



	Vinyl Open Air	Vinyl	Vinyl High Resolution
E-TECHNOLOGY			
Supply voltage	100 - 240 V AC 50/60 Hz	100 - 240 V AC 50/60 Hz	100 - 240 V AC 50/60 Hz
Fuse	2 × T 1.6 A L 250 V	2 × T 1.6 A L 250 V	2 × T 1.6 A L 250 V
Power consumption	max. 60 W	max. 60 W	max. 60 W
Connections	1 × USB 1 × power	1 × USB 1 × power	1 × USB 1 × power
Cables & plugs USB	1.8 m A/B	1.8 m A/B	1.8 m A/B
Mains	2.5 m AC 110/230 V E+F CEE 7/7	2.5 m AC 110/230 V E+F CEE 7/7	2.5 m AC 110/230 V E+F CEE 7/7
TEMPERATURE			
Operation:	18°C - 30°C	18°C - 30°C	18°C - 30°C
Storage	-5°C - 50°C	-5°C - 50°C	-5°C - 50°C
MEASUREMENT			
High-resolution camera	No	No	Yes
HR Mode resolution	—	—	2.8 Mpx
LR Mode resolution	1,3 Mpx	1,3 Mpx	1.4 Mpx
Camera	Point Grey	Point Grey	Point Grey
3D measuring technology	Stripe light triangulation with white light LED	Stripe light triangulation with white light LED	Stripe light triangulation with blue light LED
Measuring field XYZ mm ≅ max. object size in the universal mode	80 × 60 × 85	80 × 60 × 85	80 × 60 × 85
Measuring accuracy According to ISO 12836	6 µm	6 µm	4 µm
MeasurementScanning of complete jaw	LR Mode 16 seconds Processing 13 seconds Overall time 29 seconds	LR mode 16 seconds 13 seconds 29 seconds	HR Mode* 18 seconds 17 seconds 35 seconds
			* LR Mode as Vinyl



		Vinyl Open Air	Vinyl	Vinyl High Resolution
Measurement of single stump	Scanning	LR mode 33 seconds	LR mode 33 seconds	HR mode* 35 seconds
	Processing	08 seconds	08 seconds	14 seconds
	Overall time	41 seconds	41 seconds	49 seconds
				* LR Mode as Vinyl
Measurement of 3-unit bridge	Scanning	LR mode 45 seconds	LR mode 45 seconds	HR mode* 50 seconds
	Processing	22 seconds	22 seconds	25 seconds
	Overall time	67 seconds	67 seconds	75 seconds
				* LR mode as Vinyl
Measurement universal Ø	Scanning	45 seconds	45 seconds	50 seconds
	Processing	22 seconds	22 seconds	25 seconds
	Overall time	67 seconds	67 seconds	75 seconds

SYSTEM REQUIREMENTS (PC & CAD-SOFTWARE AVAILABLE EXTRA)

PC (Minimum)	CPU: i3 with 4 × 3.6 GHz RAM: 16 GB Port: USB 3.0 HDD: 40 – 100 GB Graphics card RAM: 1 GB	CPU: i3 with 4 × 3.6 GHz RAM: 16 GB Port: USB 3.0 HDD: 40 – 100 GB Graphics card RAM: 1 GB	CPU: i5 with 4 × 3.8 GHz RAM: 32 GB Port: USB 3.0 HDD: 100 – 250 GB Graphics card RAM: 6 MB
PC (recommended)	CPU: i7 with 6 × 4.7 GHz RAM: 32 GB Port: USB 3.0 HDD: 100 -250 GB Graphics card RAM: 6 MB	CPU: i7 with 6 × 4.7 GHz RAM: 32 GB Port: USB 3.0 HDD: 100 -250 GB Graphics card RAM: 6 MB	CPU: i7 with 6 × 4.7 GHz RAM: 32 GB Port: USB 3.0 HDD: 100 -250 GB Graphics card RAM: 6 MB
Operating system (Minimum)	Windows 7 (64-Bit)	Windows 7 (64-Bit)	Windows 10 (64-Bit)
Operating system (recommended)	Windows 10 (64-Bit)	Windows 10 (64-Bit)	Windows 10 (64-Bit)
dental Scan	as of version 3.0.0	as of version 3.0.0	as of version 3.1.0
CAD-Software	exocad® DentalCAD (all versions)	exocad® DentalCAD (all versions)	exocad® DentalCAD (all versions)



19. Declaration of CE conformity



smart optics Sensortechnik GmbH
Lise-Meitner-Allee 10
44801 Bochum, Germany

Declaration of CE- Conformity

According to EU-regulation 2006/42/EG Appendix II A

We declare that the device identified below complies with the requirements of the EU guideline which regard to safety and physical health requirements both in concept and construction put in circulation.

This declaration becomes invalid in case of an unauthorized change of the device.

Device description:	Optical 3D scanner
Device type:	Vinyl
EU guidelines applicable:	machine guideline (2006/42/EG) low voltage guideline (2014/35/EU) EMC guideline (2014/30/EG)

Harmonized standards applied:
DIN EN ISO 12100:2010 Safety of machinery
DIN EN 61326-1:2013
DIN EN 61010-1:2010

The CE label was used first for this product in 2017.

Document prepared by: Jörg Friemel

Bochum, 22.05.2017

smart optics
Sensortechnik GmbH
Lise-Meitner-Allee 10
D-44801 Bochum / Germany
Fon: +49 234 29 82 8-0 Fax: -20



20. Short guide to commissioning

Chapter 5 Detailed work steps and explanations:
Setup and Commissioning of the Scanner

Workstation



Table's load-bearing capacity: 46 kg
Scanner's space requirements BxHxD mm:
455 x 430 x 420 - 455 x 660 x 470



PC with recommended configuration
CPU: i7 with 6 x 4.7 GHz
RAM: 32 GB
Port: USB 3.0
HDD: 100 -250 GB



Graphics card 6 MB RAM

Windows 10 64 Bit

Unpacking



► Tools required



► Observe the display and the instructions

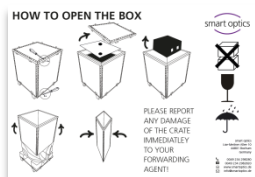

► Follow the description

► Keep the packaging



Carrying

Step 4



- ▶ 2 persons recommended.
- ▶ Position sideways
- ▶ or: 1 person behind the device



- ▶ Hold the device under its edges



- ▶ Tilt the device slightly backwards

Connection

Step 5

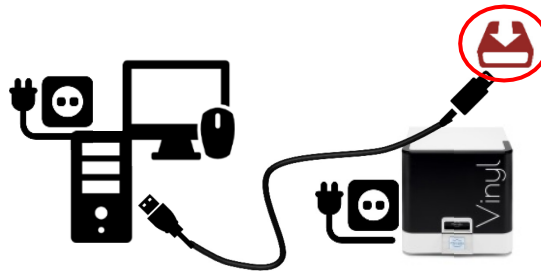

- ▶ Connect the power cable
- ▶ Connect the USB cable



- ▶ Switch on (rear)

Installation

Step 9



dental Scan installation



Use of dental Scan



- ▶ Copy the data carrier locally



dental Scan.exe

- ▶ Install the software.



- ▶ Start the software.
- ▶ Load the calibration data.



- ▶ Calibrate: Fasten the model
- ▶ Insert #1 and #2



Ready to scan!



21. Glossary

3D Scan	Three-dimensional image of the model in the software.
3D sensor	Electronic component for three-dimensional measurement. The 3D sensor is not movable.
Articulator	Dental tool for fabricating a condyle-related occlusion. Articulators are available from various manufacturers. The most common articulators can be scanned condyle-related with the scanners of the Vinyl series.
Blue light/white light	LED light used for measurements.
Calibration	A metrological term. A) alignment of the scanner to the values of an industrially calibrated model. B) alignment of the motion axes with regard to the individual calibration data.
Calibration model	Industrially measured model which is used for calibrating the scanner.
Height alignment	Positioning of the model in the measuring field of the 3D sensor with the aid of the z-axis.
HR mode	High-resolution scanning.
Lens	Optical component of the camera.
Measurement	Calculation of the surface which can be measured through the projection of stripe light. Triangulation is the measuring principle.
Measuring field	Size of the maximum area which can be captured by the 3D sensor.
Model	A model which is scanned, e.g. the impression of a plaster jaw.



Multisplit base plate	Permanently mounted magnetic plate onto which the Multisplit mounting plates, object holders and adapter plates can be fastened.
Object holder	A holder on which the object to be measured (e.g. jaw model) is mounted and which itself is then mounted to the base in the scanner.
Occlusion clamp	Special holder for smart optics scanners with which a non-articulated jaw model is placed inside the scanner. The occlusion clamp is used for easy fastening of occlusion models.
Rotary axis	<p>One of the motion axes of the scanner. The base can be rotated.</p> <p>Free rotation of the base allows full circumferential positioning in front of the camera.</p>
Stripe light	A striped pattern which is projected on the model to measure the surface three-dimensionally.
Swivel axis	<p>One of the motion axes of the scanner. The swivel axis moves sideways so that the model is positioned in front of the camera at different angles.</p> <p>The swivel axis carries the rotary axis.</p>
Triangulation	Measuring method for determining the position of a point in space with the help of triangles.
Universal Mode	Use of the scanner for non-dental purposes.
Z-axis	One of the motion axes of the scanner. The z-axis moves up and down so that the model is positioned in front of the camera at different heights.

22. Index

μ

μ (Unit of measurement) 8

3

3D scan spray 11, 45

 Use 45

3D sensor 76

A

Accessories 36

 Scope of delivery 24

Adapter 48

 Articulator 26, 48, 49, 50

 multiDie/multiCase 62, 63, 64

 Scope of delivery 24

 Triple Tray® 65

Adhesive pads 52, 62, 70

Application (as intended) 11

Articulated jaw model 49, 50

Articulator 59

 Adapter 48, 49, 50

 Insert/remove 60, 61

 Manufacturer 28

 Single jaw model 46, 48

ASCII (data format) 9

Axes 31

B

Blue light 76

Box (Transport) 36

C

Cable 41

Cabling 41

CAD software 85

Calibration 79

Calibration data 24

Calibration model 74

Case (accessories) 36

Caution (convention) 10

CE

 Conformity 86

 Labelling 22

Clamp

 Occlusion 57

 Triple Tray® 65

Clasp forceps 57

Cleaning 80

Cleaning agents 80

Code of response 21

Colors

 Status LED 33

Colors (material) 11

Comma

 Notation of numbers 8

Connections

 Mains 35, 41

 USB 35, 41

Conventions 6

Cover 43

D

Data carrier 24

Defect

 Calibration model 74

 Device 21, 81

Denominations

 Accessories 33

 Adapter plate 48

 Articulator 59

 Calibration model 74

 Exterior view 29

 Internal view 31, 32, 44

 multiDie Adapter 62

 Object holder 51

 Occlusion clamp 57

 Rear view 35

 System plate 45

 Touchscreen 30

 Triple Tray® impression holder 65

dental Scan 77, 79

 Scope of delivery 24

Depth of the device 83

Dimensions (technical data) 83

DIN standards 86

Display 30, 77

Disposal

 Device 82

 Environment 82

 Packaging 82

E

Electromagnetic compatibility.....	36
EMC	
Directive.....	86
Labelling.....	22
Workstation.....	36
Environment.....	12, 82
Error.....	21, 81
EU Directives.....	86

F

Fastening the calibration model inside the scanner .	75
Fault.....	21, 81
Fuse.....	22
Fuse (technical data).....	84

G

Gingiva.....	54
Gingival sculpture.....	54
Grounding or protective grounding.....	23

H

Handle (Lid).....	43
Height of the device.....	83
High Resolution (Vinyl).....	24
Holder	
Articulator.....	59
Mounting plate.....	46, 49
multiDie/multiCase.....	62
Object holder.....	51, 69
Occlusion.....	55
Triple Tray®.....	65
Hz (technical data).....	84

I

Impression	
Clamping.....	65
Insert/remove.....	67, 68
Injuries (Protective measures).....	13
Inserting tooth stumps individually.....	62
Installation.....	24

J

Jaw model	
Fasten with occlusion clamp.....	57
Fasten with rubber band.....	55
Fastened inside the scanner.....	46, 48, 52, 55, 60

Fastened with an articulator.....	59
With gingiva.....	54
With scanbody.....	54
With squeeze bite.....	54
With wax-up.....	54

K

kg (technical data).....	83
kg (unit of measurement).....	8
Knurled screw.....	52, 57, 74

L

LED (white/blue).....	76
Lifting (scanner).....	38, 39
Lifting points.....	38, 39
Low Voltage Directive.....	86
LR and HR mode.....	79

M

Machine Directive.....	86
Mains connection.....	35
Maintenance.....	79
Manuals (types).....	5
Material (colors).....	11
Material damages (Protective measures).....	16
Matting (surface).....	45
Measured values (Calibration model).....	74
Measuring accuracy.....	79, 84
Measuring field (technical data).....	84
mm (Unit of measurement).....	8
Model holder.....	24
Mounting plate	
Connect to adapter plate.....	49
Direct insertion.....	46
MSH (data format).....	9
multiDie/multiCase	
Adhesive pads.....	62
Fasten tooth stumps.....	62
Module.....	62
Scope of delivery.....	24
Slots.....	62

N

Note (convention).....	10
Number (Calibration model).....	74
Numbers	
Decimal system.....	8

O

Object	
Fastening inside the scanner	70
Object holder	51, 69
Adapter	48
Articulator	59
Fasten gingiva	54
Fasten scanbody	54
Fasten squeeze bite	54
Fasten wax-up	54
Fastening a jaw model	46, 52, 55
Fastening objects	70
Fastening the calibration model	75
Insert/remove	49, 50, 63
Insertion	53, 72
Mounting plate	46, 49
multiDie/multiCase	62
Occlusion clamp	57
Removal	54, 64, 73
Rubber band	55
Scope of delivery	24
Objects (Universal Mode)	70
Occlusion	59
Fasten the model with an articulator	59
With occlusion clamp	57
With rubber band	55
Occlusion clamp	57
Occupational safety	12
Open Air (Vinyl)	24
Opening and closing	43
Operating manuals (types)	5
Operating the lid	43
Optics:	31, 32, 80

P

Packaging	36
Parts	
Accessories	33
Adapter plate	48
Articulator	59
Calibration model	74
Exterior view	29
Internal view	31, 32, 44
multiDie Adapter	62
Object holder	51
Occlusion clamp	57
Rear view	35
System plate	45
Touchscreen	30
Triple Tray® impression holder	65
PC (Scope of delivery)	

Optional	26
PC (technical data)	85
PCM (data format)	9
PLY (data format)	9
Positioning	
Calibration model	74
Objects (Universal)	69
Occlusion model	55, 59
Single jaw model	46
Tooth stump (individual tooth)	62
Triple Tray® impression	65
Positioning items	69
Positioning objects	69
Power cable	24
Power consumption (technical data)	84
Pre-treatment of dark surfaces	45
Pre-treatment of glossy surfaces	45
Protective measures	13, 16, 21

R

Removing dirt	80
Repair	81
Representation	6
Requirements (workstation)	36
Rubber band	55

S

Safety	12–21
Correct response	21
Design	12
Injuries	13
Material damages	16
Symbols	22
Touching	22
User qualification	12
Scanbody	54
Scanning	
Principle	76
Starting with the touchscreen	77
Scope of delivery	24
Sensor number	35, 81
Serial number	35, 81
Setup	
Dimensions	36
Location	36
Weight	36
Slot (multiDie Adapter)	62
Slots (multiDie Adapter)	62
SO number	35, 81
Software	77, 79
Scope of delivery	24

Squeeze bite 54
Standards (EU Directives)..... 86
Standards (Safety) 12
Status LED 33
STL (data format) 9
Storage temperature (technical data)..... 84
Striped pattern..... 76
Supply voltage (technical data) 84
Symbols 6
System plate 32, 44, 45

T

Tick (symbol)..... 6
Tip (convention) 6
Touchscreen 30, 77
Training 12
Triangle (symbol)..... 6
Triple Tray®
 Clamp 65
 Insert/remove 67, 68
 Scope of delivery 24
Triple Tray® impression scan 65
Type plate..... 35, 81

U

Units of measurement
 International System of Units 8

Universal Mode..... 69, 70
Unpacking 36
USB cable 24
Use (as intended) 11

V

V (Technical specifications)..... 84
Vacuuming 80
Vestibular scan (occlusion) 55, 59
Vinyl High Resolution 79

W

Warning (convention) 10
Warranty 81
Watt (technical data)..... 84
Wax-up 54
WEEE..... 82
Weight (technical data)..... 83
White light 76
Width of the device 83
Windows (technical data)..... 85
Workstation..... 36



Manufacturer

smart optics Sensortechnik GmbH
Lise-Meitner-Allee 10
D-44801 Bochum, Germany



reddot award 2018
winner

ID: SO-20900-OMBA-90334-90351-90400-EN

www.smartoptics.de

